



CLIMATE  
ACTION  
RESERVE

# **Landfill Project Protocol**

Collecting and Destroying Methane from Landfills

***Version 3.0***

December 2, 2009

## Table of Contents

Abbreviations and Acronyms .....	1
1 Introduction .....	3
2 The GHG Reduction Project .....	4
2.1 Background .....	4
2.2 Project Definition .....	4
2.3 The Project Developer .....	5
3 Eligibility Rules .....	6
3.1 Location .....	6
3.2 Project Start Date .....	6
3.3 Project Crediting Period .....	6
3.4 Additionality .....	7
3.4.1 The Performance Standard Test .....	7
3.4.2 The Legal Requirement Test .....	8
3.5 Regulatory Compliance .....	11
4 The GHG Assessment Boundary .....	12
5 Quantifying GHG Emission Reductions .....	17
5.1 Quantifying Baseline Emissions .....	18
5.2 Quantifying Project Emissions .....	25
6 Project Monitoring .....	28
6.1 Monitoring Requirements .....	28
6.2 Instrument QA/QC .....	30
6.3 Missing Data .....	31
6.4 Monitoring Parameters .....	31
7 Reporting Parameters .....	40
7.1 Project Documentation .....	40
7.2 Record Keeping .....	40
7.3 Reporting Period & Verification Cycle .....	41
8 Verification Guidance .....	42
8.1 Standard of Verification .....	42
8.2 Monitoring Plan .....	42
8.3 Verifying Project Eligibility .....	42
8.4 Core Verification Activities .....	43
8.5 Landfill Project Verification Items .....	44
8.5.1 Project Eligibility and CRT Issuance .....	44
8.5.2 Quantification of GHG Emission Reductions .....	45
8.5.3 Risk Assessment .....	46
8.6 Completing Verification .....	46
9 Glossary of Terms .....	47
10 References .....	50
Appendix A Development of the Performance Standard Threshold .....	52
Appendix B Development of the NMOC Emissions Threshold .....	54
Purpose .....	54
Data .....	54
Summary .....	54
Methodology .....	55
Results .....	57

Appendix C Emission Factor Tables ..... 59

Appendix D Pre-Project Monitoring and Calculation of LFG<sub>PP1</sub> and PP<sub>CH4</sub> ..... 63

    Baseline Monitoring ..... 63

    Monitoring ..... 63

    Passive Flare Configuration ..... 64

    Calculation ..... 64

    Example ..... 65

Appendix E Data Substitution Guidelines ..... 67

## List of Tables

Table 4.1. Summary of Identified Sources, Sinks and Reservoirs .....	14
Table 6.1. Monitoring Data to be Collected and Used to Estimate Emission Reductions.....	32
Table 8.1. Summary of Eligibility Criteria .....	43
Table 8.2. Eligibility Verification Items .....	44
Table 8.3. Quantification Verification Items .....	45
Table 8.4. Risk Assessment Verification Items.....	46
Table A.1. Summary of Information on U.S. landfills (NSPS/EG and Non-NSPS/EG).....	53
Table A.2. Summary of Non-NSPS/EG Landfills under Assumption that Flare Only Landfills Are Already Regulated .....	53
Table B.1. Quotes from Vendors/Engineering Firms for the Cost of Flare, Transportation, Installation, and Basic Instrumentation .....	57
Table B.2. Summary of Install and Monthly Carbon Costs for Carbon Adsorption Systems at 14 Landfills.....	58
Table C.1. CO <sub>2</sub> Emission Factors for Fossil Fuel Use .....	59
Table C.2. CO <sub>2</sub> Electricity Emission Factors.....	60
Table C.3. Default Destruction Efficiencies for Combustion Devices .....	62
Table D.1. Example Dataset and Calculation of Closed <sub>discount</sub> or NQ <sub>discount</sub> .....	66

## List of Figures

Figure 4.1. General Illustration of the GHG Assessment Boundary .....	13
Figure 6.1. Suggested Arrangement of LFG Metering Equipment.....	29

## List of Equations

Equation 5.1. Calculating GHG Emission Reductions .....	18
Equation 5.2. Adjusting the Landfill Gas Flow for Temperature and Pressure .....	18
Equation 5.3. Calculating Baseline Emissions.....	20
Equation 5.4. Total Methane Emissions Destroyed .....	21
Equation 5.5 Pre-Project Adjustment for Destruction in the Baseline Scenario.....	22
Equation 5.6. Calculating Pre-Project Adjustment for Destruction in a Qualifying Flare at a Closed Landfill .....	23
Equation 5.7. Calculating Pre-Project Adjustment for Non-Qualifying Devices .....	23
Equation 5.8. Calculating Pre-Project Adjustment for Qualifying Devices .....	24
Equation 5.9. Calculating Project Emissions .....	26
Equation 5.10. Calculating Project Emissions from Fossil Fuel Use .....	26
Equation 5.11. Calculating Project Emissions from Electricity Use .....	27
Equation 5.12. Calculating Project Emissions from the Use of Supplemental Fuel.....	27
Equation D.1. Calculation of Pre-Project Discount for a Non-Qualifying Device .....	65

## Abbreviations and Acronyms

ACF	Actual cubic feet
CAA	Clean Air Act
CARB	California Air Resources Board
CEQA	California Environmental Quality Act
CH <sub>4</sub>	Methane
CIWMB	California Integrated Waste Management Board
CNG	Compressed natural gas
CO <sub>2</sub>	Carbon dioxide
EG	Emission Guidelines
EPA	U.S. Environmental Protection Agency
FFG	Supplemental natural gas
GHG	Greenhouse gas
IPCC	Intergovernmental Panel on Climate Change
LFG	Landfill gas
LNG	liquefied natural gas
MG	Mega gram (1,000,000 grams or one tonne, or “t”)
MSW	Municipal solid waste
N <sub>2</sub> O	Nitrous oxide
NEPA	National Environmental Policy Act
NESHAP	National Emission Standards for Hazardous Air Pollutants
NG	Natural gas
NMOC	Non-methane organic compounds
NSPS	New Source Performance Standards
NSR	New Source Review
PSD	Prevention of Significant Deterioration
QA/QC	Quality Assurance/Quality Control

RCRA	Resources Conservation and Control Act
Reserve	Climate Action Reserve
SCF	Standard cubic feet (60°F and 1 atm)
VOC	Volatile organic compound

# 1 Introduction

The Climate Action Reserve (Reserve) Landfill Project Protocol provides guidance to account for and report greenhouse gas (GHG) emission reductions associated with installing a landfill gas collection and destruction system at a landfill.

The Climate Action Reserve is a national offsets program working to ensure integrity, transparency and financial value in the U.S. carbon market. It does this by establishing regulatory-quality standards for the development, quantification and verification of GHG emissions reduction projects in North America; issuing carbon offset credits known as Climate Reserve Tonnes (CRT) generated from such projects; and tracking the transaction of credits over time in a transparent, publicly-accessible system. Adherence to the Reserve's high standards ensures that emissions reductions associated with projects are real, permanent and additional, thereby instilling confidence in the environmental benefit, credibility and efficiency of the U.S. carbon market.

The Climate Action Reserve operates as a program under the similarly named nonprofit organization. Two other programs, the Center for Climate Action and the California Climate Action Registry, also operate under the Climate Action Reserve.

Project developers that install landfill gas capture and destruction technologies use this document to register GHG reductions with the Reserve. This protocol provides eligibility rules, methods to calculate reductions, performance-monitoring instructions, and procedures for reporting project information to the Reserve. Additionally, all project reports receive annual, independent verification by ISO-accredited and Reserve-approved verification bodies. Guidance for verification bodies to verify reductions is provided in the Verification Program Manual and the corresponding Landfill Project Verification Protocol.

This protocol is designed to ensure the complete, consistent, transparent, accurate, and conservative quantification of GHG emission reductions associated with a landfill project.<sup>1</sup>

Project developers must comply with all local, state, and federal municipal solid waste (MSW), air and water quality regulations in order to register GHG reductions with the Reserve. To register GHG reductions with the Reserve, project developers are not required to take an annual entity-level GHG inventory of their MSW operations.

---

<sup>1</sup> See the WRI/WBCSD GHG Protocol for Project Accounting (Part I, Chapter 4) for a description of GHG accounting principles.

## 2 The GHG Reduction Project

### 2.1 Background

Most MSW in the United States is deposited in landfills, where bacteria decompose the organic material. A product of both the bacterial decomposition and oxidation of solid waste is landfill gas, which is composed of methane (CH<sub>4</sub>) and carbon dioxide (CO<sub>2</sub>) in approximately equal concentrations, as well as smaller amounts of non-methane organic compounds (NMOC), nitrogen (N<sub>2</sub>), oxygen (O<sub>2</sub>) and other trace gases. If not collected and destroyed, over time, this landfill gas is released to the atmosphere. In the United States, the Environmental Protection Agency (EPA) has concluded that landfills are the largest source of anthropogenic emissions of CH<sub>4</sub>, accounting for 25 percent of total CH<sub>4</sub> emissions.<sup>2</sup> However, the solid waste industry has made significant efforts to reduce their GHG emissions over the past 20 years.<sup>3</sup>

There is considerable uncertainty regarding the actual amount of fugitive methane emissions from landfills. Therefore, this protocol does not address fugitive landfill methane emissions. Instead, it addresses the methane that is captured and destroyed in excess of any regulatory requirements.

### 2.2 Project Definition

For the purpose of this protocol, the GHG reduction project is the use of an eligible qualifying device for destroying methane gas collected at an eligible landfill. Qualifying destruction devices consist of utility flares, enclosed flares, engines, boilers, pipelines, vehicles, or fuel cells. An eligible landfill is one that:

1. Is not subject to regulations or other legal requirements requiring the destruction of methane gas; and
2. Is not a bioreactor, as defined by the US EPA: “a MSW landfill or portion of a MSW landfill where any liquid other than leachate (leachate includes landfill gas condensate) is added in a controlled fashion into the waste mass (often in combination with recirculating leachate) to reach a minimum average moisture content of at least 40 percent by weight to accelerate or enhance the anaerobic (without oxygen) biodegradation of the waste”<sup>4</sup>; and
3. Does not add any liquid other than leachate into the waste mass in a controlled manner.

Captured landfill gas may be destroyed on-site, transported for off-site use (e.g. through gas distribution or transmission pipeline), or used to power vehicles. Regardless of how project developers use the captured landfill gas, for the project to be eligible to register with the Reserve under this protocol, the ultimate fate of the methane must be destruction.<sup>5</sup>

Landfill gas collection and destruction systems typically consist of wells, pipes, blowers, caps and other technologies that enable or enhance the collection of landfill gas and convey it to a destruction technology. At some landfills, a flare will be the only device where landfill gas is

<sup>2</sup> U.S. Environmental Protection Agency, Inventory of U.S. Greenhouse Gas Emissions and Sinks: 1990-2005, EPA-430-R-07-002 (April 2007).

<sup>3</sup> The updated Draft California Greenhouse Gas Inventory, developed by the Air Resources Board (August 2007), shows significant improvement in fugitive methane emission control at landfills within the state of California.

<sup>4</sup> 40 CFR 63.1990 and 40 CFR 258.28a.

<sup>5</sup> It is possible that at some point landfill gas may be used in the manufacture of chemical products. However, given that these types of projects are few, if any, these projects are not addressed in this protocol.



destroyed. For projects that utilize energy or process heat technologies to destroy landfill gas, such as turbines, reciprocating engines, fuel cells, boilers, heaters, or kilns, these devices will be where landfill gas is destroyed. Most projects that produce energy or process heat also include a flare to destroy gas during periods when the gas utilization project is down for repair or maintenance. Direct use arrangements which entail the piping of landfill gas to be destroyed by an industrial end user at an off-site location are also an eligible approach to destruction of the landfill gas. For instances of direct use, agreements between the project developer and the end user of the landfill gas (i.e. an industrial client purchasing the landfill gas from the project developer), must include a legally binding agreement to assure that the GHG reductions will not be claimed by more than one party.

Projects that utilize landfill methane for energy generation may avoid GHG emissions associated with fossil fuel combustion. However, under this protocol such projects do not receive credit for fossil fuel displacement. Although the Reserve does not issue CRTs for fossil fuel displacement, it strongly supports using landfill methane for energy production.

### **2.3 The Project Developer**

The “project developer” is an entity that has an active account on the Reserve, submits a project for listing and registration with the Reserve, and is ultimately responsible for all project reporting and verification. Project developers may be landfill owners, landfill operators, GHG project financiers, utilities, or independent energy companies. The project developer must have clear ownership of the project’s GHG reductions. Ownership of the GHG reductions must be established by clear and explicit title, and the project developer must attest to such ownership by signing the Reserve’s Attestation of Title form.<sup>6</sup>

---

<sup>6</sup> Attestation of Title form available at <http://www.climateactionreserve.org/how/projects/register/project-submittal-forms/>.

### 3 Eligibility Rules

Projects that meet the definition of a GHG reduction project in Section 2.2 must fully satisfy the following eligibility rules in order to register with the Reserve.

<b>Eligibility Rule I:</b>	Location	→	<i>U.S. and its territories</i>
<b>Eligibility Rule II:</b>	Project Start Date	→	<i>January 1, 2001*</i>
<b>Eligibility Rule III:</b>	Additionality	→	<i>Meet performance standard</i>
		→	<i>Exceed legal requirements</i>
<b>Eligibility Rule IV:</b>	Regulatory Compliance	→	<i>Compliance with all applicable laws</i>

\* See Section 3.2 for more details on project start date

#### 3.1 Location

Under this protocol, only projects located at landfills in the United States and its territories are eligible to register with the Reserve.<sup>7</sup>

#### 3.2 Project Start Date

The start date for a landfill project is defined as the date that methane gas was first continuously destroyed in a qualifying destruction device, regardless of whether sufficient monitoring data is available to report reductions. The start date is defined in relation to the commencement of methane destruction, not other activities that may be associated with project initiation or development.

To be eligible, the project must be submitted to the Reserve no more than six months after the project start date, unless the project is submitted during the first 12 months following the date of adoption of Version 2.0 of the Landfill Project Protocol by the Reserve board (the Effective Date, or November 17, 2008).<sup>8</sup> For a period of 12 months from the Effective Date, projects with start dates as early as January 1, 2001 are eligible to register. Projects may always be submitted for listing by the Reserve prior to their start date.

#### 3.3 Project Crediting Period

The Reserve will issue CRTs for GHG reductions quantified and verified using this protocol for a period of ten years following the project start date. However, the Reserve will cease to issue CRTs for GHG reductions if at any point in the future landfill gas collection and destruction becomes legally required at the landfill. If an eligible project has begun operation at a landfill that later becomes subject to a regulation, ordinance or permitting condition that would call for the installation and operation of a landfill gas control system, the Reserve will issue CRTs for GHG reductions achieved up until the date that the landfill gas control system is legally required to be operational.

<sup>7</sup> Refer to Appendix A for information on the performance standard analysis supporting application of this protocol in the United States.

<sup>8</sup> Projects are considered submitted when the project developer has fully completed and filed the appropriate Project Submittal Form, available on the Reserve's website.

The project crediting period begins when the landfill gas collection and destruction system becomes operational regardless of whether sufficient monitoring data is available to verify GHG reductions.

### 3.4 Additionality

The Reserve strives to register only projects that yield surplus GHG reductions that are additional to what would have occurred in the absence of a carbon offset market.

Projects must satisfy the following tests to be considered additional:

1. The Performance Standard Test
2. The Legal Requirement Test

#### 3.4.1 The Performance Standard Test

Projects pass the Performance Standard Test by meeting a performance threshold, i.e. a standard of performance applicable to all landfill projects, established on an ex-ante basis by this protocol.<sup>9</sup>

For this protocol, the Reserve uses a technology-specific threshold (or “practice-based” threshold), which serves as “best practice standard” for managing landfill gas fugitive emissions. A project passes the Performance Standard Test if it involves any of the following activities:

1. Installation of a landfill gas collection system and a new qualifying destruction device at an eligible landfill where landfill gas has never been collected and destroyed prior to the project start date.
2. Installation of a new qualifying destruction device at an eligible landfill where landfill gas is currently collected and vented, but has never been destroyed in any manner prior to the project start date.
3. Installation of a new qualifying destruction device at an eligible landfill where landfill gas was collected and destroyed at any time prior to the project start date using:
  - a. A non-qualifying destruction device (e.g. passive flares); or
  - b. A destruction device that is not otherwise eligible under the protocol (e.g. a destruction device installed prior to the earliest allowable project start date).
4. Installation of additional wells at an eligible closed landfill where landfill gas was collected and destroyed prior to the project start date using a qualifying flare (or flares) that is not otherwise eligible under the protocol (e.g. a flare installed prior to the earliest allowable project start date). The project is only eligible if a qualifying flare continues to be used to destroy collected methane.<sup>10</sup> Installation of additional flares, or flare upgrades, is permitted under this provision, provided that all destruction devices at the landfill site are flares. Only incremental gas collection and destruction (beyond baseline levels) is eligible for crediting.

---

<sup>9</sup> The Reserve defined the performance standard based upon an evaluation of landfill practices in the United States. A summary of the performance standard analysis is provided in Appendix A.

<sup>10</sup> Projects only pass the Performance Standard Test if the device is a qualifying flare, not a beneficial use destruction device.

Destruction devices that were installed temporarily and utilized only for pilot or testing purposes shall not be considered in determining project eligibility.

Changes in landfill ownership, or in the ownership of destruction devices, are not considered in determining prior landfill gas management practices. If landfill gas was previously collected and destroyed by a party other than the project developer, it still qualifies as “prior” collection and destruction.

Under scenarios (1), (2) and (3) above, a project must involve the installation of a new qualifying destruction device. In these cases, expanding a well-field (either in conjunction with, or subsequent to, installing a new destruction device) constitutes a system expansion rather than a separate project. Expanding a well-field is eligible as a new, separate project only if it meets the conditions described in scenario (4). In these cases, expanding a well-field initiates a new crediting period.

The Performance Standard Test is applied at the time a project applies for registration with the Reserve. Once a project is registered, it does not need to be evaluated against future versions of the protocol or the Performance Standard Test for the duration of its crediting period. The Reserve will periodically re-evaluate the appropriateness of the performance standard threshold by updating the market penetration analysis in Appendix A.

The Reserve recognizes the importance of waste diversion and recycling programs. Therefore, as part of its periodic assessments of the performance threshold, the Reserve will use a stakeholder process to evaluate whether implementation of this protocol has resulted in negative environmental effects, such as increased emissions of criteria pollutants and/or methane. The assessment will pay particular attention to the status of other GHG reduction project protocols including composting, anaerobic digestion, recycling and waste-to-energy, which would act to balance and complement the Landfill Project Protocol. If it is determined that negative environmental effects have occurred, the Reserve will identify and implement revisions to the protocol to prevent such effects from occurring in the future, or may suspend implementation of the protocol if necessary.

### **3.4.2 The Legal Requirement Test**

All projects are subject to a Legal Requirement Test to ensure that the GHG reductions achieved by a project would not otherwise have occurred due to federal, state, or local regulations, or other legally binding mandates. Projects pass the Legal Requirement Test when there are no laws, statutes, regulations, court orders, environmental mitigation agreements, permitting conditions, or other legally binding mandates requiring the destruction of landfill gas methane at the project site.<sup>11</sup> To satisfy the Legal Requirement Test, project developers must submit a signed Regulatory Attestation form<sup>12</sup> prior to the commencement of verification activities each time the project is verified. In addition, the project’s Monitoring Plan (Section 6) must include procedures that the project developer will follow to ascertain and demonstrate that the project at all times passes the Legal Requirement Test.

---

<sup>11</sup> A project may pass the Legal Requirement Test if a landfill gas control system is installed to treat landfill gas for NMOC in order to comply with a regulation, ordinance, or permitting condition, but destruction of the landfill gas is not the only compliance mechanism available to the landfill operator, and the total mass flow of NMOC for the landfill gas control system is less than the applicable NMOC threshold (see Section 3.4.2.3).

<sup>12</sup> Regulatory Attestation form available at <http://www.climateactionreserve.org/how/projects/register/project-submittal-forms/>.

Landfills currently collecting and destroying landfill gas to comply with regulations or other legal mandates – or that are currently required by regulation or legal mandate to install a landfill gas control system in the future – are not eligible to register new projects with the Reserve. Landfills currently collecting and destroying landfill gas to comply with regulations or other legal mandates are not eligible to register GHG reductions associated with the early installation of gas control systems during landfill expansion into new cells.

If an eligible project begins operation at a landfill that later becomes subject to a regulation, ordinance, or permitting condition that calls for the installation of a landfill gas control system, GHG reductions may be reported to the Reserve up until the date that the installation of a landfill gas control system is legally required to be operational. If the landfill's methane emissions are included under an emissions cap (e.g. under a state or federal cap-and-trade program), emission reductions may likewise be reported to the Reserve until the date that the emissions cap takes effect.

### **3.4.2.1 Federal Regulations**

There are several EPA regulations for MSW landfills that have a bearing on the eligibility of methane collection and destruction projects as voluntary GHG reduction projects. These regulations include:

- New Source Performance Standards (NSPS) for MSW Landfills, codified in 40 CFR 60 subpart WWW – Targets landfills that commenced construction or made modifications after May 1991
- Emission Guidelines (EG) for MSW Landfills, codified in 40 CFR 60 subpart Cc. – Targets existing landfills that commenced construction before May 30, 1991, but accepted waste after November 8, 1987
- The National Emission Standards for Hazardous Air Pollutants (NESHAP), codified in 40 CFR 63 subpart AAAA – Regulates new and existing landfills

These regulations require control of non-methane organic compounds (NMOC) from landfills according to certain size and emission thresholds. In most cases, activities to reduce NMOC will also lead to a reduction in CH<sub>4</sub> emissions, as gas collection and destruction is a common NMOC management technique employed at regulated landfills.

Landfills with a design capacity of at least 2.5 million megagrams and 2.5 million cubic meters of municipal solid waste are subject to the NSPS or EG rules. Landfills above the design capacity size cutoff must calculate their annual NMOC emissions using equations or procedures in the NSPS or EG rules. The landfill must install a gas collection and control system within 30 months after the first annual NMOC emissions rate report in which the emissions rate equals or exceeds 50 Mg/yr. A landfill is subject to the NESHAP if the design capacity is at least 2.5 million megagrams and 2.5 million cubic meters of municipal solid waste, and it has estimated uncontrolled emissions equal to or greater than 50 Mg/yr NMOC as calculated according to Section 60.754(a) of the NSPS or U.S. EPA-approved federal, state or tribal plan.

Landfills smaller than 2.5 million megagrams or 2.5 million cubic meters of waste, and those landfills not defined as MSW landfills such as landfills that contain only construction and demolition material or industrial waste, are not usually subject to NSPS, EG or NESHAP.

### 3.4.2.2 State and Local Regulations, Ordinances and Permitting Requirements

All states are required by the Clean Air Act (CAA) and Subtitle D of the Resource Conservation and Control Act (RCRA Subtitle D) to promulgate rules for landfills. Some landfills that exceed applicable emission thresholds will require site-specific permits requiring controls under the New Source Review (NSR) or Prevention of Significant Deterioration (PSD) permitting program authorized by the CAA and implemented by states. These state-level rules generally follow federal guidelines. However, the state rules can be more stringent, or require the installation of a gas collection and destruction system, or the destruction of volatile organic compounds (VOC), NMOC, or CH<sub>4</sub> earlier, or at smaller facilities, than the federal regulations would require.

For example, on June 21, 2007, California Air Resources Board (CARB) approved a Landfill Methane Capture Strategy as a discrete early action measure. Accordingly, CARB staff, in collaboration with California Integrated Waste Management Board (CIWMB) staff, is currently developing a control measure to provide enhanced control of methane emissions from landfills. The control measure will reduce methane emissions from landfills by requiring gas collection and control systems where these systems are not currently required, and will establish statewide performance standards to maximize methane capture efficiencies.<sup>13</sup>

In recent years the inclusion of air quality, water quality and even GHG emission control measures in permitting requirements (CEQA, NEPA, etc.) has become more prevalent. State and local governments may regulate MSW landfills by putting in place nuisance laws or requiring solid waste facilities smaller than the facilities regulated by the CAA or RCRA Subtitle D to control landfill gas. Other regulations or ordinances may require minimal gas collection to prevent lateral migration of the landfill gas to neighboring properties. Collection and destruction activities required under NSPS, EG, NESHAP, CAA and other state and local regulations, ordinances or permitting requirements are not eligible as GHG reduction projects.<sup>14</sup>

The Reserve acknowledges that non-CAA programs such as RCRA Subtitle D, water quality regulations and other state and local regulations, ordinances or permitting requirements do not always dictate the installation of a landfill gas collection system as the only compliance mechanism to manage NMOC emissions or VOC water contamination, but that the installation of a landfill gas collection system is commonly the most effective and least demanding compliance mechanism available. Therefore, the installation of a landfill gas collection and destruction system for compliance with non-CAA regulations will not qualify as a GHG reduction project under this protocol unless these projects also meet the eligibility requirements discussed below.

Some water quality, explosive gas mitigation, and local nuisance regulations and ordinances allow for passive landfill gas control systems, which collect and vent landfill gas to the atmosphere, but are not required to treat or destroy the vented gases. Project activities that add a destruction device to a landfill that is only required to implement a passive landfill gas control system pass the Legal Requirement Test.

---

<sup>13</sup> California Air Resources Board, Landfill Methane Control Measure webpage: <http://www.arb.ca.gov/cc/ccea/landfills/landfills.htm>.

<sup>14</sup> The Reserve acknowledges that the third party verifier will need to exercise some discretion when reviewing permits that require the installation of a landfill gas control system or any portion thereof. Permits tend to include strong language, such as "must" or "shall" install a landfill gas control system, even in the case that a landfill chooses to voluntarily install a landfill gas control system but is required to obtain a permit to do so.

### 3.4.2.3 NMOC Threshold

Certain water quality, explosive gas mitigation, and local nuisance regulations or ordinances require landfill gas collection systems. Once the landfill gas is collected and vented, the landfill may then become subject to air quality regulations requiring the control of NMOC emissions. In some instances, the air quality regulations may allow for flexibility in the treatment of landfill gas for NMOC using either destruction devices or other systems such as carbon adsorption (for the latter, the methane would be vented to atmosphere). Even in the regulatory situation where carbon adsorption is a compliance option, oftentimes a landfill gas destruction device will be the preferred compliance mechanism. Where it is determined that the destruction system is the preferred option, the landfill gas control system in question will not pass the Legal Requirement Test.

The Reserve has developed an NMOC emissions threshold to determine the eligibility of projects at landfills where treatment of landfill gas for NMOC is required in order to comply with a regulation, ordinance, or permitting condition, but destruction of the landfill gas is not the only compliance mechanism available to the landfill operator.<sup>15</sup> The applicable threshold depends on whether or not closed flares are required by law at the landfill (e.g. by air district or local regulations). Specifically:

1. For sites at which closed flares are not required by law, a project is eligible if the total mass flow of NMOC for the landfill gas control system is less than 1,775 pounds NMOC per month.
2. For sites at which closed flares are required by law, a project is eligible if the total mass flow of NMOC for the landfill gas control system is less than 2,575 pounds NMOC per month.

By default, projects must use the lower of the two thresholds. In order to use the higher threshold, the project developer must demonstrate to the satisfaction of a Reserve-approved verification body that an open flare could not be permitted at the landfill in question.

If the total mass flow of NMOC for the landfill gas control system is greater than the applicable NMOC threshold, then the landfill gas control system is not eligible as a GHG reduction project under this protocol.

## 3.5 Regulatory Compliance

As a final eligibility requirement, project developers must attest that the project is in material compliance with all applicable laws (e.g. air, water quality, safety, etc.) prior to verification activities commencing each time a project is verified. Project developers are required to disclose in writing to the verifier any and all instances of non-compliance of the project with any law. If a verifier finds that a project is in a state of recurrent non-compliance or non-compliance that is the result of negligence or intent, then CRTs will not be issued for GHG reductions that occurred during the period of non-compliance. Non-compliance solely due to administrative or reporting issues, or due to “acts of nature,” will not affect CRT crediting.

---

<sup>15</sup> A summary of the development of the NMOC emissions threshold is provided in Appendix B.

## 4 The GHG Assessment Boundary

The GHG Assessment Boundary delineates the GHG sources, sinks and reservoirs (SSRs) that shall be assessed by project developers in order to determine the total net change in GHG emissions caused by a landfill project.

This protocol does not account for carbon dioxide emission reductions associated with displacing grid-delivered electricity or fossil fuel use.

CO<sub>2</sub> emissions associated with the generation and destruction of landfill gas are considered biogenic emissions<sup>16</sup> (as opposed to anthropogenic) and are not be included in the GHG Assessment Boundary. This is consistent with the Intergovernmental Panel on Climate Change's (IPCC) guidelines for captured landfill gas.<sup>17</sup>

Figure 4.1 below provides a general illustration of the GHG Assessment Boundary, indicating which SSRs are included or excluded from the boundary. All SSRs within the dashed line are accounted for under this protocol.

Table 4.1 provides greater detail on each SSR and provides justification for the inclusion or exclusion of SSRs and gases from the GHG Assessment Boundary.

---

<sup>16</sup> The rationale is that carbon dioxide emitted during combustion represents the carbon dioxide that would have been emitted during natural decomposition of the solid waste. Emissions from the landfill gas control system do not yield a net increase in atmospheric carbon dioxide because they are theoretically equivalent to the carbon dioxide absorbed during plant growth.

<sup>17</sup> *IPCC Good Practice Guidance and Uncertainty Management in National Greenhouse Gas Inventories*; p.5.10, ftnt.



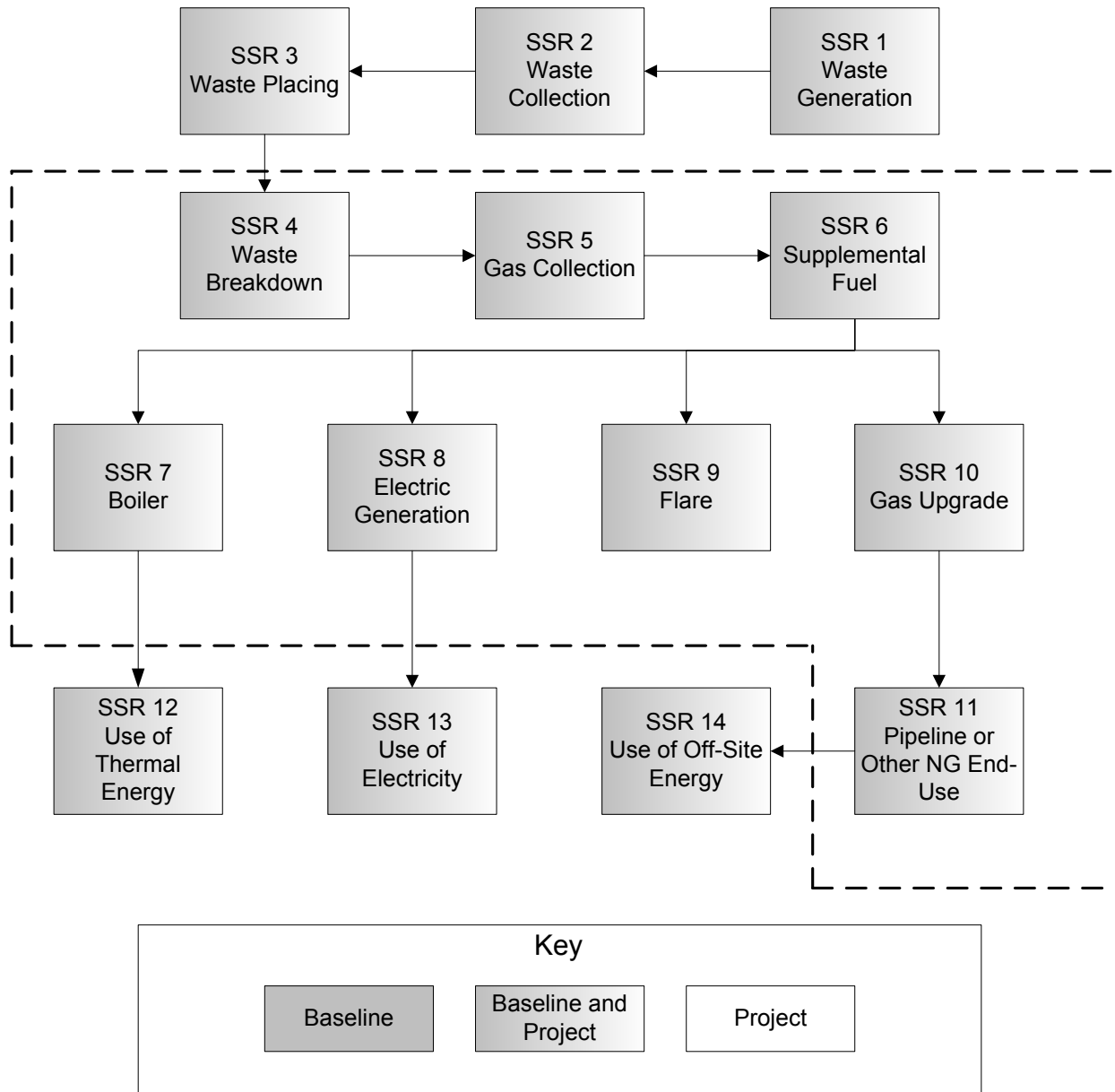

Figure 4.1. General Illustration of the GHG Assessment Boundary

**Table 4.1.** Summary of Identified Sources, Sinks and Reservoirs

SSR	Source	Gas	Relevant to Baseline (B) or Project (P)	Included/ Excluded	Justification/Explanation
1	Emissions from Waste Generation	N/A	B,P	Excluded	GHG emissions from this source are assumed to be equal in the baseline and project scenarios
2	Emissions from Waste Collection	CO <sub>2</sub>	B,P	Excluded	GHG emissions from this source are assumed to be equal in the baseline and project scenarios
		CH <sub>4</sub>		Excluded	GHG emissions from this source are assumed to be equal in the baseline and project scenarios
		N <sub>2</sub> O		Excluded	GHG emissions from this source are assumed to be equal in the baseline and project scenarios s
3	Emissions from Waste Placing Activities	CO <sub>2</sub>	B,P	Excluded	GHG emissions from this source are assumed to be equal in the baseline and project scenarios
		CH <sub>4</sub>		Excluded	GHG emissions from this source are assumed to be equal in the baseline and project scenarios
		N <sub>2</sub> O		Excluded	This emission source is assumed to be equal in the baseline and project scenarios
4	Emissions from Waste Breakdown in Landfill	CO <sub>2</sub>	B,P	Excluded	Biogenic CO <sub>2</sub> emissions are excluded
		CH <sub>4</sub>		Included	Primary source of GHG emissions in baseline. Calculated based on destruction in pre-project and project destruction devices.
5	Emissions from Gas Collection System	CO <sub>2</sub>	P	Included	Landfill projects result in CO <sub>2</sub> emissions associated with the energy used for collection and processing of landfill gas
		CH <sub>4</sub>		Excluded	This emission source is assumed to be very small
		N <sub>2</sub> O		Excluded	This emission source is assumed to be very small
	Emissions from Pre-Project Gas Collection System	CO <sub>2</sub>	B	Excluded	This emission source is assumed to be very small
		CH <sub>4</sub>		Excluded	This emission source is assumed to be very small
		N <sub>2</sub> O		Excluded	This emission source is assumed to be very small
6	Emissions from Supplemental Fuel	CO <sub>2</sub>	P	Included	Landfill projects may require use of supplemental fossil fuel, resulting in significant new GHG emissions
		CH <sub>4</sub>		Included	Calculated based on destruction efficiency of destruction device
		N <sub>2</sub> O		Excluded	This emission source is assumed to be very small
	Emissions from Pre-Project Supplemental Fuel Use	CO <sub>2</sub>	B	Excluded	This emission source is assumed to be very small
		CH <sub>4</sub>		Excluded	This emission source is assumed to be very small
		N <sub>2</sub> O		Excluded	This emission source is assumed to be very small

SSR	Source	Gas	Relevant to Baseline (B) or Project (P)	Included/ Excluded	Justification/Explanation
7	Emissions from Project LFG Boiler Destruction	CO <sub>2</sub>	P	Excluded	Biogenic CO <sub>2</sub> emissions are excluded
		CH <sub>4</sub>		Included	Calculated in reference to destruction efficiency
		N <sub>2</sub> O		Excluded	This emission source is assumed to be very small
	Emissions from pre-Project LFG Boiler Destruction	CO <sub>2</sub>	B	Excluded	Biogenic CO <sub>2</sub> emissions are excluded
		CH <sub>4</sub>		Included	Calculated in reference to destruction efficiency
		N <sub>2</sub> O		Excluded	This emission source is assumed to be very small
8	Emissions from Project LFG Electricity Generation	CO <sub>2</sub>	P	Excluded	Biogenic CO <sub>2</sub> emissions are excluded
		CH <sub>4</sub>		Included	Calculated in reference to destruction efficiency
		N <sub>2</sub> O		Excluded	This emission source is assumed to be very small
	Emissions from pre-Project LFG Electricity Generation	CO <sub>2</sub>	B	Excluded	Biogenic CO <sub>2</sub> emissions are excluded
		CH <sub>4</sub>		Included	Calculated in reference to destruction efficiency
		N <sub>2</sub> O		Excluded	This emission source is assumed to be very small
9	Emissions from Project LFG Flare Destruction	CO <sub>2</sub>	P	Excluded	Biogenic CO <sub>2</sub> emissions are excluded
		CH <sub>4</sub>		Included	Calculated in reference to destruction efficiency
		N <sub>2</sub> O		Excluded	This emission source is assumed to be very small
	Emissions from pre-Project LFG Flare Destruction	CO <sub>2</sub>	B	Excluded	Biogenic CO <sub>2</sub> emissions are excluded
		CH <sub>4</sub>		Included	Calculated in reference to destruction efficiency
		N <sub>2</sub> O		Excluded	This emission source is assumed to be very small
10	Emissions from Upgrade of LFG	CO <sub>2</sub>	P	Included	Landfill projects may result in GHG emissions from additional energy used to upgrade landfill gas
		CH <sub>4</sub>		Excluded	This emission source is assumed to be very small
		N <sub>2</sub> O		Excluded	This emission source is assumed to be very small
11	Emissions from Project LFG Pipeline or other NG end-use	CO <sub>2</sub>	P	Excluded	Biogenic emissions are excluded
		CH <sub>4</sub>		Included	Calculated in reference to destruction efficiency
		N <sub>2</sub> O		Excluded	Assumed to be very small
	Emissions from pre-Project LFG Pipeline or other NG end-use	CO <sub>2</sub>	B	Excluded	Biogenic emissions are excluded
		CH <sub>4</sub>		Included	Calculated in reference to destruction efficiency
		N <sub>2</sub> O		Excluded	This emission source is assumed to be very small
12	Use of Project Generated Thermal Energy	CO <sub>2</sub>	P	Excluded	This protocol does not cover displacement of GHG emissions from use of LFG-generated thermal energy
	Use of pre-project Generated Thermal Energy	CO <sub>2</sub>	B	Excluded	This protocol does not cover displacement of GHG emissions from use of LFG-generated thermal energy

SSR	Source	Gas	Relevant to Baseline (B) or Project (P)	Included/ Excluded	Justification/Explanation
13	Use of Project Generated Electricity	CO <sub>2</sub>	P	Excluded	This protocol does not cover displacement of GHG emissions from use of LFG-generated electricity.
	Use of pre-Project Generated Electricity	CO <sub>2</sub>	B	Excluded	This protocol does not cover displacement of GHG emissions from use of LFG-generated electricity.
14	Use of Project Thermal Energy or Power from pipeline delivered NG	CO <sub>2</sub>	P	Excluded	This protocol does not cover displacement of GHG emissions from use of LFG delivered through pipeline or other end uses
	Use of pre-Project Thermal Energy or Power from pipeline delivered NG	CO <sub>2</sub>	B	Excluded	This protocol does not cover displacement of GHG emissions from use of LFG delivered through pipeline or other end uses

## 5 Quantifying GHG Emission Reductions

GHG emission reductions from a landfill project are quantified by comparing actual project emissions to baseline emissions at the landfill. Baseline emissions are an estimate of the GHG emissions from sources within the GHG Assessment Boundary (see Section 4) that would have occurred in the absence of the landfill project. Project emissions are actual GHG emissions that occur at sources within the GHG Assessment Boundary. Project emissions must be subtracted from the baseline emissions to quantify the project's total net GHG emission reductions (Equation 5.1).

GHG emission reductions must be quantified and verified on at least an annual basis. Project developers may choose to quantify and verify GHG emission reductions on a more frequent basis if they desire. The length of time over which GHG emission reductions are quantified and verified is called the "reporting period".

The calculations provided in this protocol are derived from internationally accepted methodologies.<sup>18</sup> Project developers shall use the calculation methods provided in this protocol to determine baseline and project GHG emissions in order to quantify GHG emission reductions.

Models that estimate biological and physical processes, such as the biological decomposition of solid waste in landfills and the migration of the landfill gas to the atmosphere are becoming increasingly refined and available. Process models typically rely on a series of input data that research has shown to be important drivers of the biological and geochemical process. In terms of GHG emission models, process models identify the mathematical relationships between inputs, basic conditions, and GHG emissions. The procedure for modeling landfills can be quite complex and subject to many different interpretations of how to address site-specific landfill gas generation factors and how to apply models effectively to landfills. At this time, no widely accepted method exists for determining the total amount of uncontrolled landfill gas emissions to the atmosphere from landfills. As new technologies and/or widely accepted modeling methods become available for the estimation of fugitive methane emissions from landfills, the Reserve will consider updating the protocol to incorporate these new approaches into the methane emission reduction quantification methodologies.

---

<sup>18</sup> The Reserve's GHG reduction calculation method is derived from the Kyoto Protocol's Clean Development Mechanism (ACM0001 V.6 and AM0053 V.1), the EPA's Climate Leaders Program (Draft Landfill Offset Protocol, October 2006), the GE AES Greenhouse Gas Services Landfill Gas Methodology V.1, and the RGGI Model Rule (January 5, 2007).

**Equation 5.1.** Calculating GHG Emission Reductions

$ER = BE - PE$		
<i>Where,</i>		<u>Units</u>
ER	= GHG emission reductions of the project activity during the reporting period	tCO <sub>2</sub> e
BE	= Baseline emissions during the reporting period	tCO <sub>2</sub> e
PE	= Project emissions during the reporting period	tCO <sub>2</sub> e

If any of the landfill gas flow metering equipment does not internally correct for the temperature and pressure of the landfill gas, separate pressure and temperature measurements must be used to correct the flow measurement. Corrected values must be used in all of the equations of this section. Apply Equation 5.2 only if the landfill gas flow metering equipment does not internally correct for temperature and pressure.

**Equation 5.2.** Adjusting the Landfill Gas Flow for Temperature and Pressure

$LFG_{scf} = LFG_{unadjusted} \times \frac{520}{T} \times \frac{P}{1}$		
<i>Where,</i>		<u>Units</u>
LFG <sub>scf</sub>	= Adjusted volume of landfill gas collected for the given time interval, measured at 60° F and 1 atm	scf
LFG <sub>unadjusted</sub>	= Unadjusted volume of landfill gas collected for the given time interval	acf
T	= Measured temperature of the landfill gas for the given time period (°R = °F + 460)	°R
P	= Measured pressure of the landfill gas in for the given time interval	atm

**5.1 Quantifying Baseline Emissions**

Traditional baseline emission calculations are not required for this protocol for the quantification of methane reductions. The baseline scenario assumes that all uncontrolled methane emissions are released to the atmosphere except for the portion of methane that would be oxidized by bacteria in the soil of uncovered landfills absent the project,<sup>19</sup> or destroyed by a pre-project destruction device. Therefore, with the exception of the deductions outlined below, baseline emissions are equal to the sum of all methane destroyed by eligible destruction devices.

<sup>19</sup> Landfill cover systems incorporating synthetic liners as part of the final cover systems should use a default methane oxidation rate of zero. A 10% methane oxidation factor shall be used for all other landfills. A small portion of the methane generated in landfills (around 10%) is naturally oxidized to carbon dioxide by methanotrophic bacteria in the cover soils of well managed landfills. The 10% factor is based on Intergovernmental Panel on Climate Change (IPCC) guidelines (2006).

As noted in Section 3.4.1, projects may fall into four categories based on the pre-project state of the landfill and level of landfill gas management. Each of these categories requires a slightly different methodology for calculating relevant baseline emissions.

1. Landfills where no previous collection or destruction took place prior to the project start date must deduct the following from baseline emissions:
  - a. The amount of methane that would have been oxidized by soil bacteria in the absence of the project.
2. Landfills where previous collection and/or destruction took place in a non-qualifying destruction device must deduct the following from baseline emissions:
  - a. The amount of methane destroyed by the non-qualifying destruction device.
  - b. The amount of methane that would have been oxidized by soil bacteria in the absence of the project.
3. Landfills where previous collection and destruction took place in a qualifying destruction device must deduct the following from baseline emissions:
  - a. The amount methane that could have been destroyed if the pre-project destruction device was operating at full capacity.
  - b. The amount of methane that would have been oxidized by soil bacteria in the absence of the project.
4. Closed landfills where previous collection and destruction took place in a qualifying flare must deduct the following from baseline emissions:
  - a. The amount of methane collected by pre-project landfill gas wells and destroyed in the qualifying flare.
  - b. The amount of methane that would have been oxidized by soil bacteria in the absence of the project.

These conditions ensure that the reductions resulting from the GHG project can be accounted for separately from collection and destruction that would have occurred from the pre-project equipment. Only the landfill gas destroyed beyond what would have been destroyed by the pre-project collection and destruction system is considered eligible for crediting.

Baseline emissions shall be calculated using Equation 5.3.

**Equation 5.3. Calculating Baseline Emissions**

$$BE = (CH_4 Dest_{PR}) \times 21 \times (1 - OX) \times (1 - DF) - Dest_{base}$$

Where,

		<u>Units</u>
BE	= Baseline emissions during the reporting period	tCO <sub>2</sub> e
CH <sub>4</sub> Dest <sub>PR</sub>	= Total methane destroyed by the project landfill gas collection and destruction system during the reporting period (see Equation 5.4)	tCH <sub>4</sub>
21	= Global Warming Potential factor of methane to carbon dioxide equivalent <sup>20</sup>	
OX	= Factor for the oxidation of methane by soil bacteria. Equal to 0.10 for all landfills except those that are covered with a synthetic liner as part of the final cover systems where OX = 0	
Dest <sub>base</sub>	= Adjustment to account for pre-project LFG destruction device (see Equation 5.5). Equal to zero if no pre-project LFG destruction system is in place prior to project implementation	tCO <sub>2</sub> e
DF	= Discount factor to account for uncertainties associated with the monitoring equipment. Either 0, 0.10, or 0.20 (see Section 6.1). Equal to zero if using continuous methane monitoring	

The term CH<sub>4</sub>Dest<sub>PR</sub> represents the amount of methane destroyed by the project. This term is calculated according to Equation 5.4.

<sup>20</sup> IPCC Second Assessment Report: Climate Change 1996.



**Equation 5.4. Total Methane Emissions Destroyed**

$$CH_4 Dest_{PR} = \sum_i (CH_4 Dest_i) \times (0.0423 \times 0.000454)$$

Where,

	<u>Units</u>
$CH_4 Dest_{PR}$ = Total methane destroyed by the project landfill gas collection and destruction system during the reporting period	tCH <sub>4</sub>
$CH_4 Dest_i$ = The net quantity of methane destroyed by destruction device i (flare, engine, boiler, upgrade, etc.) during the reporting period	scf CH <sub>4</sub>
0.0423 = Density of methane	lbCH <sub>4</sub> / scf CH <sub>4</sub>
0.000454 = Conversion factor	tCH <sub>4</sub> / lbCH <sub>4</sub>

And,

$$CH_4 Dest_i = Q_i \times DE_i$$

Where,

	<u>Units</u>
$CH_4 Dest_i$ = The net quantity of methane destroyed by device i during the reporting period	scf
$Q_i$ = Total quantity of landfill methane sent to destruction device i during the reporting period	scf
$DE_i$ = Default methane destruction efficiency for device i. <sup>21,22</sup> See Appendix C for default factors	

And,

$$Q_i = \sum_t [LFG_{i,t} \times PR_{CH_4,t}]$$

Where,

$Q_i$ = Total quantity of landfill methane sent to destruction device i during the reporting period	scf
$LFG_{i,t}$ = Total quantity of landfill gas fed to the destruction device i, in time interval t	scf/t
t = Time interval for which LFG flow and concentration measurements are aggregated. Equal to one day for continuously monitored methane concentration and one week for weekly monitored methane concentration	
$PR_{CH_4,t}$ = The average methane fraction of the landfill gas in time interval t as measured	scf CH <sub>4</sub> / scf LFG

<sup>21</sup> If available, the official source tested methane destruction efficiency shall be used in place of the default methane destruction efficiency. Otherwise, project developers have the option to use either the default methane destruction efficiencies provided, or the site specific methane destruction efficiencies as provided by a state or local agency accredited source test service provider, for each of the combustion devices used in the project case.

<sup>22</sup> The default destruction efficiencies for enclosed flares and electricity generation devices are based on a preliminary set of actual source test data provided by the Bay Area Air Quality Management District. The default destruction efficiency values are the lesser of the twenty fifth percentile of the data provided or 0.995. These default destruction efficiencies may be updated as more source test data is made available to the Reserve.

For projects where methane was destroyed in the baseline, Equation 5.5 must be applied. This equation accounts for the methane emissions calculated in Equation 5.4 which would have been destroyed in the absence of the project activity.

Any project at a landfill where methane was collected and destroyed at any time prior to the project start date – even if the prior collection and/or destruction system was removed or has been dormant for an extended period of time – must apply the pre-project deduction.

**Equation 5.5** Pre-Project Adjustment for Destruction in the Baseline Scenario

$Dest_{base} = (Closed_{discount} + NQ_{discount} + Dest_{max}) \times 0.0423 \times 0.000454 \times 21$		
Where,		<u>Units</u>
$Dest_{base}$	= Adjustment to account for the baseline methane destruction associated with a pre-project destruction device. Equal to zero if there is no pre-project installation	tCO <sub>2</sub> e
$Closed_{discount}$	= Adjustment to account for the methane that would have been combusted in the baseline flare from pre-project wells at a closed landfill. Equal to zero if the project is not a flare project at a closed landfill	scf CH <sub>4</sub>
$NQ_{discount}$	= Adjustment to account for the methane that would have been combusted in the baseline, non-qualifying combustion device. Equal to zero if there is no non-qualifying combustion device	scf CH <sub>4</sub>
$Dest_{max}$	= Deduction of the un-utilized capacity of the pre-project destruction device. This deduction is to be applied only when a new destruction device is used during project activity. See Box 5.1 below for an example of the application of the $Dest_{max}$ adjustment	scf CH <sub>4</sub>
0.0423	= Density of methane	lbCH <sub>4</sub> / scf CH <sub>4</sub>
0.000454	= Conversion factor	
21	= Global Warming Potential factor of methane to carbon dioxide equivalent	tCH <sub>4</sub> / lbCH <sub>4</sub>

**Equation 5.6.** Calculating Pre-Project Adjustment for Destruction in a Qualifying Flare at a Closed Landfill

$Closed_{discount} = LFG_{PP1} \times PP_{CH_4}$		
Where,		<u>Units</u>
Closed <sub>discount</sub>	= Adjustment to account for the methane which would have been combusted in the baseline flare from pre-project wells at a closed landfill. Equal to zero if the project is not a flare project at a closed landfill	scf CH <sub>4</sub>
LFG <sub>PP1</sub>	= Landfill gas from the pre-project landfill gas wells that would have been destroyed by the qualifying destruction system during the reporting period. See Appendix D for guidance on calculating LFG <sub>PP1</sub>	scf
PP <sub>CH4</sub>	= Methane fraction of landfill gas destroyed by the collection system during the reporting period. See Appendix D for guidance on calculating PP <sub>CH4</sub>	scf CH <sub>4</sub> / scf LFG

**Equation 5.7.** Calculating Pre-Project Adjustment for Non-Qualifying Devices

$NQ_{discount} = LFG_{PP2} \times PP_{CH_4}$		
Where,		<u>Units</u>
NQ <sub>discount</sub>	= Adjustment to account for the methane that would have been combusted in the baseline, non-qualifying combustion device. Equal to zero if there is no non-qualifying combustion device	scf CH <sub>4</sub>
LFG <sub>PP2</sub>	= Landfill gas that would have been destroyed by the original, non-qualifying destruction system during the reporting period. See Appendix D for guidance on calculating LFG <sub>PP2</sub>	scf
PP <sub>CH4</sub>	= Methane fraction of landfill gas destroyed by the original collection system. See Appendix D for guidance on calculating PP <sub>CH4</sub>	scf CH <sub>4</sub> / scf LFG

**Equation 5.8.** Calculating Pre-Project Adjustment for Qualifying Devices

$$Dest_{max} = \sum_t \left[ (LFG_{PPmax,t} - LFG_{PP3,t}) \times PR_{CH_4,t} \right]$$

Where,

Units

Dest <sub>max</sub>	= Deduction of the un-utilized capacity of the pre-project destruction device. This deduction is to be applied only when a new destruction device is used during project activity. See Box 5.1 below for an example of the application of the Dest <sub>max</sub> adjustment	scf CH <sub>4</sub>
LFG <sub>PPmax,t</sub>	= The maximum landfill gas flow capacity of the pre-project methane destruction device in time interval t	scf/t
LFG <sub>PP3,t</sub>	= The actual landfill gas flow of the pre-project methane destruction device in time interval t	scf/t
PR <sub>CH<sub>4</sub>,t</sub>	= The average methane fraction of the landfill gas in time interval t as measured	scf CH <sub>4</sub> /scf LFG
t	= Time interval for which LFG flow and concentration measurements are aggregated. Equal to one day for continuously monitored methane concentration and one week for weekly monitored methane concentration	

**Box 5.1. Applying the Dest<sub>max</sub> Adjustment**

This adjustment was designed to help differentiate system upgrades from additional projects, while encouraging project developers to use their landfill gas beneficially. In short, this methodology assumes that any gas which *could* have been destroyed in the pre-project qualifying device is not additional; diversion of that gas to a new destruction device represents an upgrade. Therefore, this term deducts from calculated project reductions that portion of gas which, in the absence of the new destruction device, still could have been destroyed.

**Example:**

A flare with a capacity of 1000 cfm was installed at a landfill in 1998. Therefore, because this flare was operational before 2001, the landfill gas control system is ineligible as a project under this protocol. However, in 2005, an electric generator with a 2000 cfm capacity was installed, and all landfill gas was diverted to this device. The addition of the electric generator meets the eligibility requirements of this protocol, and therefore qualifies as a new project. Because the pre-project flare is a qualifying destruction device under this protocol and is not eligible as a project due to other eligibility criteria (i.e. operational date), it must be accounted for using Dest<sub>max</sub>.

In 2005, 900 cfm was sent to generator, and 0 cfm was sent to the flare. In the year 2006, due to landfill expansion and installation of additional wells, the generator destroyed 1400 cfm while the flare was non-operational. In 2007, further well expansion allowed the generator to operate at full capacity and the flare was used to destroy an additional 300 cfm of landfill gas.

**Calculations:**

Year	Generator Destruction (cfm)	Flare Capacity (cfm)	Flare Destruction (cfm)	Deduction (cfm)	Project Reductions (cfm)
2005	900	1000	0	1000	-100 (0)
2006	1400	1000	0	1000	400
2007	1800	1000	300	700	1100

**Note:** this example and the calculations are significantly simplified for illustrative purposes. The example values are calculated on a cubic feet per minute of landfill gas basis. Reporters are actually required to report the cumulative value of methane gas sent to the destruction device for each time interval t.

## 5.2 Quantifying Project Emissions

Project emissions must be quantified at a minimum on an annual, *ex-post* basis. As shown in Equation 5.9, project emissions equal:

- Total indirect carbon dioxide emissions resulting from consumption of electricity from the grid related to project activities
- Total carbon dioxide emissions from the on-site destruction of fossil fuel related to project activities
- Total carbon dioxide emissions from the combustion of supplemental natural gas
- Total methane emissions from the incomplete combustion of supplemental natural gas

Project emissions shall be calculated using Equation 5.9.

**Equation 5.9. Calculating Project Emissions**

$$PE = FF_{CO_2} + EL_{CO_2} + FF_{CH_4}$$

Where,

		<u>Units</u>
PE	= Project emissions during the reporting period	tCO <sub>2</sub> e
FF <sub>CO2</sub>	= Total carbon dioxide emissions from the destruction of fossil fuel during the reporting period	tCO <sub>2</sub>
EL <sub>CO2</sub>	= Total indirect carbon dioxide emissions from the consumption of electricity from the grid during the reporting period	tCO <sub>2</sub>
FF <sub>CH4</sub>	= Total quantity of emissions from supplemental natural gas, including both uncombusted methane and carbon dioxide emissions during the reporting period	tCO <sub>2</sub>

**Equation 5.10. Calculating Project Emissions from Fossil Fuel Use**

$$FF_{CO_2} = \frac{\sum_j (FF_{PR,j} \times EF_{FF,j})}{1000}$$

Where,

		<u>Units</u>
FF <sub>CO2</sub>	= Total carbon dioxide emissions from the destruction of fossil fuel during the reporting period	tCO <sub>2</sub>
FF <sub>PR,j</sub>	= Total fossil fuel consumed by the project landfill gas collection and destruction system during the reporting period, by fuel type j	volume fossil fuel
EF <sub>FF,j</sub>	= Fuel specific emission factor. See Appendix C	kgCO <sub>2</sub> /volume fossil fuel
1000	= Conversion factor	kgCO <sub>2</sub> /tCO <sub>2</sub>

**Equation 5.11.** Calculating Project Emissions from Electricity Use

$$EL_{CO_2} = \frac{(EL_{PR} \times EF_{EL})}{2204.62}$$

Where,

	<u>Units</u>
$EL_{CO_2}$ = Total indirect carbon dioxide emissions from the consumption of electricity from the grid during the reporting period	tCO <sub>2</sub>
$EL_{PR}$ = Total electricity consumed by the project landfill gas collection and destruction system during the reporting period	MWh
$EF_{EL}$ = CO <sub>2</sub> emission factor for electricity used. See Appendix C	lbCO <sub>2</sub> / MWh
2204.62 = Conversion factor	lbCO <sub>2</sub> / tCO <sub>2</sub>

**Equation 5.12.** Calculating Project Emissions from the Use of Supplemental Fuel

$$FF_{CH_4} = \sum_i \left[ FF_i \times \left[ \left( (1 - DE_i) \times 0.0423 \times 0.000454 \times 21 \right) + \left( DE_i \times \frac{12}{16} \times \frac{44}{12} \right) \right] \right] \times FFG_{CH_4}$$

Where,

	<u>Units</u>
$FF_{CH_4}$ = Total emissions from supplemental natural gas during the reporting period, including both uncombusted methane and carbon dioxide emissions	tCO <sub>2</sub> e
$FF_i$ = Total quantity of supplemental natural gas delivered to the destruction device i during the reporting period	scf
$DE_i$ = Methane destruction efficiency of destruction device i. See Appendix C	
$FFG_{CH_4}$ = Average methane fraction of the supplemental natural gas as provided for by fuel vendor	scf CH <sub>4</sub> / scf FFG
0.0423 = Density of methane	lbCH <sub>4</sub> / scf CH <sub>4</sub>
0.000454 = Conversion factor	tCH <sub>4</sub> / lbCH <sub>4</sub>
21 = Global Warming Potential factor of methane to carbon dioxide equivalent	
12/16 = Carbon ratio of methane	C/CH <sub>4</sub>
44/12 = Carbon ratio of carbon dioxide	CO <sub>2</sub> /C

## 6 Project Monitoring

The Reserve requires a Monitoring Plan to be established for all monitoring and reporting activities associated with the project. The Monitoring Plan will serve as the basis for verifiers to confirm that the stipulations of this section and Section 7 have been and will continue to be met, and that consistent, rigorous monitoring and record-keeping is ongoing at the project site. The Monitoring Plan must cover all aspects of monitoring and reporting contained in this protocol and must specify how data for all relevant parameters in Table 6.1 (below) will be collected and recorded.

At a minimum the Monitoring Plan shall stipulate the frequency of data acquisition; a record keeping plan (see Section 7.2 for minimum record keeping requirements); the frequency of instrument field check and calibration activities; and the role of the individual performing each specific monitoring activity. The Monitoring Plan shall also include QA/QC provisions to ensure that data acquisition and meter calibration are carried out consistently and with precision.

Finally, the Monitoring Plan must include procedures that the project developer will follow to ascertain and demonstrate that the project at all times passes the Legal Requirement Test (Section 3.4.2).

Project developers are responsible for monitoring the performance of the project and operating the landfill gas collection and destruction system in a manner consistent with the manufacturer's recommendations for each component of the system.

### 6.1 Monitoring Requirements

Methane emission reductions from landfill gas capture and control systems must be monitored with measurement equipment that directly meters:

- The flow of landfill gas delivered to each destruction device<sup>23</sup>, measured continuously and recorded every 15 minutes or totalized and recorded at least daily, adjusted for temperature and pressure
- The fraction of methane in the landfill gas delivered to the destruction device, measured continuously and recorded every 15 minutes and averaged at least daily (a measurement frequency less than 15 minutes, but greater than weekly may be used with application of a 10% discount in Equation 5.3)

All flow data collected must be corrected for temperature and pressure at 60° F and 1 atm. If any of the landfill gas flow metering equipment does not internally correct for the temperature and pressure of the landfill gas, separate pressure and temperature measurements must be used to correct the flow measurement. The temperature and pressure of the landfill gas must be measured continuously. Corrected values must be used in all of the equations of this section.

Apply Equation 5.2 only if the landfill gas flow metering equipment does not internally correct for temperature and pressure.

---

<sup>23</sup> A single meter may be used for multiple, identical destruction devices. In this instance, methane destruction in these units will be eligible only if both units are monitored to be operational.



The continuous methane analyzer should be the preferred option for monitoring methane concentrations, as the methane content of landfill gas captured can vary by more than 20% during a single day due to gas capture network conditions (dilution with air at wellheads, leakage on pipes, etc.).<sup>24, 25</sup> When using the alternative approach of weekly methane concentration measurement using a calibrated portable gas analyzer, project developers must account for the uncertainty associated with these measurements by applying a 10% discount factor to the total quantity of methane collected and destroyed in Equation 5.3.

Figure 6.1 represents the suggested arrangement of the landfill gas flow meters and methane concentration metering equipment.

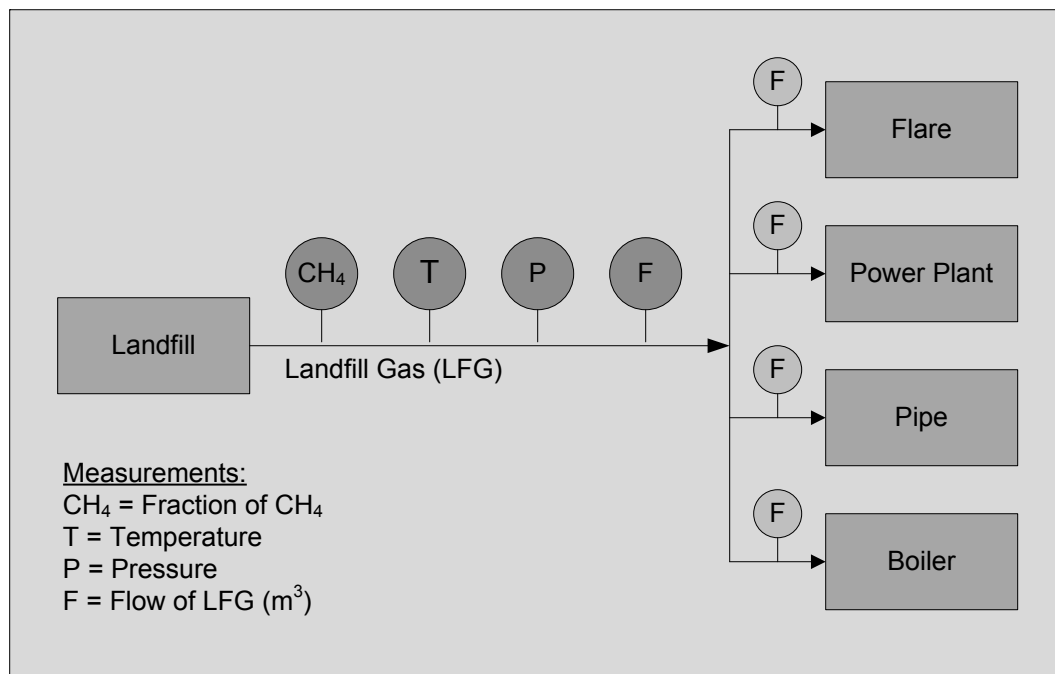

Note: The number of flow meters must be sufficient to track the total flow as well as the flow to each combustion device. The above scenario includes one more flow meter than would be necessary to achieve this objective. Source: Consolidated baseline methodology for landfill gas project activities, Clean Development Mechanism, Version 07, Sectoral Scope 13 (2007).

**Figure 6.1.** Suggested Arrangement of LFG Metering Equipment

Eligible projects may use monthly methane concentration measurements using a calibrated portable gas analyzer until January 1, 2009, after which a continuous methane analyzer or weekly measurement using a calibrated portable gas analyzer is required. In the case where monthly methane concentration measurements are used, project developers must account for the uncertainty associated with these measurements by applying a 20% discount factor to the total quantity of methane collected and destroyed.

<sup>24</sup> Methane fraction of the landfill gas to be measured on a wet/dry basis (must be measured on same basis as flow, temperature, and pressure). No separate monitoring of temperature and pressure is necessary when using flow meters that automatically correct for temperature and pressure, expressing LFG volumes in normalized cubic meters.

<sup>25</sup> Consolidated baseline methodology for landfill gas project activities, Clean Development Mechanism, Version 07, Sectoral Scope 13 (2007).

The operational activity of the landfill gas collection system and the destruction devices shall be monitored and documented at least hourly to ensure actual landfill gas destruction. GHG reductions will not be accounted for during periods which the destruction device was not operational. For flares, operation is defined as thermocouple readings above 500° F. For all other destruction devices, the means of demonstration shall be determined by the project developer and subject to verifier review.

## 6.2 Instrument QA/QC

Monitoring instruments shall be inspected, cleaned, and calibrated according to the following schedule.

All gas flow meters<sup>26</sup> and continuous methane analyzers must be:

- Cleaned and inspected on a quarterly basis<sup>27</sup>, with the activities performed and as found/as left condition of the equipment documented
- Field checked for calibration accuracy by a third-party technician with the percent drift documented, using either a portable instrument (such as a pitot tube) or manufacturer specified guidance, at the end of - but no more than two months prior to - the end date of the reporting period<sup>28</sup>
- Calibrated by the manufacturer or a certified third-party calibration service per manufacturer's guidance or every 5 years, whichever is more frequent

If the required cleaning and inspection is not performed and properly documented, no GHG credits may be generated for that quarter.

If the field check on a piece of equipment reveals accuracy outside of a +/- 5% threshold, calibration by the manufacturer or a certified service provider is required for that piece of equipment.

For the interval between the last successful field check and any calibration event confirming accuracy below the +/- 5% threshold, all data from that meter or analyzer must be scaled according to the following procedure. These adjustments must be made for the entire period from the last successful field check until such time as the meter is properly calibrated.

1. For calibrations that indicate under-reporting (lower flow rates, or lower methane concentration), the metered values must be used without correction.
2. For calibrations that indicate over-reporting (higher flow rates, or higher methane concentration), the metered values must be adjusted based on the greatest calibration drift recorded at the time of calibration.

---

<sup>26</sup> Field checks and calibrations of flow meters shall ensure that the meter accurately reads volumetric flow, and has not drifted outside of the prescribed +/-5% accuracy threshold.

<sup>27</sup> For the purposes of this protocol, quarterly is defined as once per each three month period.

<sup>28</sup> Instead of performing field checks, the project developer may instead have equipment calibrated by the manufacturer or a certified calibration service per manufacturer's guidance, at the end of but no more than two months prior to the end date of the reporting period to meet this requirement.

For example, if a project conducts field checks quarterly during a year-long reporting period, then only three months of data will be subject at any one time to the penalties above. However, if the project developer feels confident that the meter does not require field checks or calibration on a greater than annual basis, then failed events will accordingly require the penalty to be applied to the entire year's data. Further, frequent calibration may minimize the total accrued drift (by zeroing out any error identified), and result in smaller overall deductions.

In order to provide flexibility in verification, data monitored up to two months after a field check may be verified. As such, the end date of the reporting period must be no more than two months after the latest successful field check.

If a portable instrument is used (such as a handheld methane analyzer), the portable instrument shall be maintained and calibrated per the manufacturer's specifications, and calibrated at least annually by the manufacturer, by a laboratory approved by the manufacturer, or at an ISO 17025 accredited laboratory.

If available, the official source tested methane destruction efficiency shall be used in Equation 5.2 in place of the default methane destruction efficiency. Otherwise, project developers have the option to use either the default methane destruction efficiencies provided, or the site specific methane destruction efficiencies as provided by a state or local agency accredited source test service provider, for any of the destruction devices used in the project case.

### **6.3 Missing Data**

In situations where the flow rate or methane concentration monitoring equipment is missing data, the project developer shall apply the data substitution methodology provided in Appendix E. If for any reason the destruction device monitoring equipment is inoperable (for example, the thermal coupler on the flare), then no emission reductions can be registered for the period of inoperability.

### **6.4 Monitoring Parameters**

Prescribed monitoring parameters necessary to calculate baseline and project emissions are provided in Table 6.1.

**Table 6.1.** Monitoring Data to be Collected and Used to Estimate Emission Reductions

Eq. #	Parameter	Description	Data Unit	Measurement Frequency	Calculated (c) Measured (m) Reference (r) Operating records (o)	Comment
		Legal Requirement Test	Project developer attestation to compliance with regulatory requirements relating to landfill gas project	For each reporting period		Must be monitored and determined for each project period. The project developer shall document all federal, state, and local regulations, ordinances, and permit requirements (and compliance status for each) that apply to the GHG reduction project. The project developer shall provide a signed attestation to their compliance status for the above mentioned federal, state, and local regulations, ordinances, and permit requirements
		Operation of destruction device		Hourly	o	Required for each destruction device. For flares, operation is defined as thermocouple readings above 500° F
Equation 5.1	ER	GHG emission reductions during the reporting period	tCO <sub>2</sub> e		c	
Equation 5.1 Equation 5.3	BE	Baseline emissions during the reporting period	tCO <sub>2</sub> e		c	
Equation 5.1 Equation 5.9	PE	Project emissions during the reporting period	tCO <sub>2</sub> e		c	

Eq. #	Parameter	Description	Data Unit	Measurement Frequency	Calculated (c) Measured (m) Reference (r) Operating records (o)	Comment
Equation 5.3 Equation 5.4	CH <sub>4</sub> Dest <sub>PR</sub>	Total methane destroyed by the project landfill gas collection and destruction system during the reporting period	tCH <sub>4</sub>		c	
Equation 5.3	DF	Discount factor to account for uncertainties associated with the monitoring equipment	0-1.0		r	Either 0, 0.05, 0.10, 0.15, 0.20 or 0.25 (see Section 6, Project Monitoring). Equal to zero if using continuous methane monitor with no missing data and all calibration tests are within a 5% margin of error
Equation 5.3	OX	Factor for the oxidation of methane by soil bacteria	0, 0.1		r	Equal to 0.10 for all landfills except those that are covered with a synthetic liner as part of the final cover systems where OX = 0
Equation 5.3 Equation 5.5	Dest <sub>base</sub>	Adjustment to account for the baseline methane destruction associated with a pre-project destruction device	tCO <sub>2</sub> e		c	Equal to zero if no pre-project LFG destruction system is in place prior to project implementation
Equation 5.4	CH <sub>4</sub> Dest <sub>i</sub>	The net quantity of methane destroyed by destruction device i during the reporting period	scf CH <sub>4</sub>		c	

Eq. #	Parameter	Description	Data Unit	Measurement Frequency	Calculated (c) Measured (m) Reference (r) Operating records (o)	Comment
Equation 5.4	$Q_i$	Total quantity of landfill methane sent to destruction device $i$ during the reporting period	scf CH <sub>4</sub>	Daily/Weekly	c	Calculated daily if methane is continuously metered or weekly if methane is measured weekly
Equation 5.4	$DE_i$	Default methane destruction efficiency for device $i$	%	Once	r/m	Project developers have the option to use a state or local agency accredited source test service provider to test the actual methane destruction efficiency of each of the destruction devices used in the project case. If using source test data for destruction efficiencies in Equation 5.2, all source test documentation shall be provided to the verifier. See Appendix C for default values
Equation 5.4	$LFG_{i,t}$	Total quantity of landfill gas fed to the destruction device $i$ , in time interval $t$	scf/t	Continuous	m	Measured continuously by a flow meter and recorded at least once every 15 minutes. Data to be aggregated by time interval $t$
Equation 5.4	$t$	Time interval for which LFG flow and concentration measurements are aggregated	Day, week	Daily/Weekly	r	Equal to one day for continuously monitored methane concentration and one week for weekly monitored methane concentration

Eq. #	Parameter	Description	Data Unit	Measurement Frequency	Calculated (c) Measured (m) Reference (r) Operating records (o)	Comment
Equation 5.4 Equation 5.8	$PR_{CH_4,t}$	The average methane fraction of the landfill gas in time interval t	ft <sup>3</sup> CH <sub>4</sub> / ft <sup>3</sup> LFG	Continuous/ Weekly	m	Measured by continuous gas analyzer or a calibrated portable gas analyzer. Data to be averaged by time interval t. Methane fraction of the landfill gas to be measured on wet/dry basis <sup>29</sup>
Equation 5.5 Equation 5.7	$NQ_{discount}$	Adjustment to account for the methane which would have been combusted in the baseline, non-qualifying combustion device	scf CH <sub>4</sub>	Yearly	c	Calculated per year, but may be scaled for project reporting periods less than one year
Equation 5.5 Equation 5.8	$Dest_{max}$	Deduction of the un-utilized capacity of the pre-project destruction device	scf CH <sub>4</sub>	Per reporting period	c	This deduction is to be applied only when a new destruction device is used during project activity
Equation 5.5 Equation 5.6	$Closed_{discount}$	Adjustment to account for the methane which would have been combusted in the baseline flare from pre-project wells at a closed landfill	scf CH <sub>4</sub>	Yearly	c	Calculated per year, but may be scaled for project reporting periods less than one year

<sup>29</sup> Landfill gas flow, methane concentration, temperature, and pressure may be measured on either a wet or dry basis. However, all parameters must be measured and calculated in the *same* basis.

Eq. #	Parameter	Description	Data Unit	Measurement Frequency	Calculated (c) Measured (m) Reference (r) Operating records (o)	Comment
Equation 5.6	LFG <sub>PP1</sub>	Landfill gas from the pre-project landfill gas wells that would have been destroyed by the qualifying destruction system during the reporting period	scf LFG	Yearly	c	Calculated using Appendix D. Calculated per year, but may be scaled for project reporting periods less than one year
Equation 5.6 Equation 5.7 Equation 5.8	PP <sub>CH4</sub>	Methane fraction of landfill gas destroyed by the collection system during the reporting period	ft <sup>3</sup> CH <sub>4</sub> / ft <sup>3</sup> LFG	Continuously/ Weekly	m	Measured by continuous gas analyzer or a calibrated portable gas analyzer. Methane fraction of the landfill gas to be measured on wet/dry basis
Equation 5.7	LFG <sub>PP2</sub>	Landfill gas that would have been destroyed by the original, non-qualifying destruction system during the reporting period	scf LFG/yr	Yearly	c	Calculated based on the maximum flow capacity (scfm) of the destruction device, or according to guidance provided in Appendix D. Calculated per year, but may be scaled for project reporting periods less than one year
Equation 5.8	LFG <sub>PPmax,t</sub>	The maximum landfill gas flow capacity of the pre-project methane destruction device in time interval t	scf/t	At beginning of first reporting period	c	Calculated based on manufacturer's and/or engineers specifications for the destruction device and blower system. The maximum capacity of the limiting component, either the destruction device or blower, shall be used



Eq. #	Parameter	Description	Data Unit	Measurement Frequency	Calculated (c) Measured (m) Reference (r) Operating records (o)	Comment
Equation 5.8	LFG <sub>PP3, t</sub>	The actual landfill gas flow of the pre-project methane destruction device in time interval t	Scf/t	Continuous	m	Measured continuously by a flow meter and recorded at least once every 15 minutes
Equation 5.9	FF <sub>CO2</sub>	Total carbon dioxide emissions from the destruction of fossil fuel during the reporting period	tCO <sub>2</sub>	Yearly	c	
Equation 5.9	FF <sub>PR,j</sub>	Total fossil fuel consumed by the project landfill gas collection and destruction system during the reporting period, by fuel type j	volume fossil fuel	Monthly	o	Calculated from monthly record of fossil fuel purchased and consumed
Equation 5.9	EF <sub>FF,j</sub>	Fuel specific emission factor	kgCO <sub>2</sub> /volume fossil fuel	Annually	r	See Appendix C
Equation 5.9	EL <sub>CO2</sub>	Total indirect carbon dioxide emissions from the consumption of electricity from the grid during the reporting period	tCO <sub>2</sub>		c	
Equation 5.9	EF <sub>EL</sub>	Carbon emission factor for electricity used	lbCO <sub>2</sub> /MWh	Annually	r	See Appendix C

Eq. #	Parameter	Description	Data Unit	Measurement Frequency	Calculated (c) Measured (m) Reference (r) Operating records (o)	Comment
Equation 5.9	EL <sub>PR</sub>	Total electricity consumed by the project landfill gas collection and destruction system during the reporting period	MWh		m/o	Obtained from either onsite metering or utility purchase records. Required to determine CO <sub>2</sub> emissions from use of electricity to operate the project activity
Equation 5.9	FF <sub>CH4</sub>	Total quantity of emissions from supplemental natural gas, including both uncombusted methane and carbon dioxide emissions during the reporting period	tCO <sub>2</sub>	Annually	c	Includes both uncombusted methane and carbon dioxide emissions
Equation 5.9	FF <sub>i</sub>	Total quantity of supplemental natural gas delivered to the destruction device i during the reporting period	scf	Continuous	m	Metered prior to delivery to destruction device
Equation 5.9	FFG <sub>CH4</sub>	Average methane fraction of the supplemental natural gas as provided for by fuel vendor	ft <sup>3</sup> CH <sub>4</sub> / ft <sup>3</sup> FFG		r	Refer to purchase records

Eq. #	Parameter	Description	Data Unit	Measurement Frequency	Calculated (c) Measured (m) Reference (r) Operating records (o)	Comment
	T	Temperature of the landfill gas	°C	Continuous	m	No separate monitoring of temperature is necessary when using flow meters that automatically adjust flow volumes for temperature and pressure, expressing LFG volumes in normalized cubic feet.
	P	Pressure of the landfill gas	atm	Continuous	m	No separate monitoring of pressure is necessary when using flow meters that automatically measure adjust flow volumes for temperature and pressure, expressing LFG volumes in normalized cubic feet.

## 7 Reporting Parameters

This section provides guidance on reporting rules and procedures. A priority of the Reserve is to facilitate consistent and transparent information disclosure among project developers. Project developers must submit verified emission reduction reports to the Reserve annually at a minimum.

### 7.1 Project Documentation

Project developers must provide the following documentation to the Reserve in order to register a landfill gas destruction project:

- Completed Project Submittal form
- Signed Attestation of Title form
- Verification Report
- Verification Opinion
- Signed Regulatory Attestation form

Project developers must provide the following documentation each reporting period in order for the Reserve to issue CRTs for quantified GHG reductions:

- Verification Report
- Verification Opinion
- Signed Regulatory Attestation form

At a minimum, the above project documentation will be available to the public via the Reserve's online reporting tool of the same name, the Climate Action Reserve. Further disclosure and other documentation may be made available on a voluntary basis. Project submittal forms and project registration information can be found at:

<http://www.climateactionreserve.org/how/projects/register/project-submittal-forms/>.

### 7.2 Record Keeping

For purposes of independent verification and historical documentation, project developers are required to keep all information outlined in this protocol for a period of 10 years after the information is generated or 7 years after the last verification. This information will not be publicly available, but may be requested by the verifier or the Reserve.

System information the project developer should retain includes:

- All data inputs for the calculation of GHG reductions
- Copies of all solid waste, air, water, and land use permits; Notices of Violations (NOVs); and any administrative or legal consent orders dating back at least 3 years prior to the project start date, and for each subsequent year of project operation
- Project developer attestation of compliance with regulatory requirements relating to the landfill gas project
- Collection and control device information (installation dates, equipment list, etc.)
- LFG flow meter information (model number, serial number, manufacturer's calibration procedures)
- Methane monitor information (model number, serial number, calibration procedures)

- Destruction device monitor information (model number, serial number, calibration procedures)
- LFG flow data (for each flow meter)
- LFG flow meter calibration data (for each flow meter)
- Methane monitoring data
- Methane monitor calibration data
- Destruction device monitoring data (for each destruction device)
- Destruction device monitor calibration data (for each destruction device)
- CO<sub>2</sub>e monthly and annual tonnage calculations
- Copies of the results of the NSPS/EG Tier 1 and/or Tier 2 NMOC emission rate estimates and the projected date when system start-up will be required by NSPS
- Initial and annual verification records and results
- All maintenance records relevant to the LFG control system, monitoring equipment, and destruction devices

Calibrated portable gas analyzer information that the project developer should retain includes:

- Date, time, and location of methane measurement
- Methane content of LFG (% by volume) for each measurement
- Methane measurement instrument type and serial number
- Date, time, and results of instrument calibration
- Corrective measures taken if instrument does not meet performance specifications

### **7.3 Reporting Period & Verification Cycle**

Project developers must report GHG reductions resulting from project activities during each reporting period. Although projects must be verified annually at a minimum, the Reserve will accept verified emission reduction reports on a sub-annual basis, should the project developer choose to have a sub-annual reporting period and verification schedule (e.g. quarterly or semi-annually). A reporting period cannot exceed 12 months, and no more than 12 months of emission reductions can be verified at once, except during a project's first verification, which may include historical emission reductions from prior years.

Reporting periods must be contiguous; there may be no time gaps in reporting during the crediting period of a project once the initial reporting period has commenced.

## 8 Verification Guidance

This section provides verification bodies with guidance on verifying GHG emission reductions from landfill gas projects developed to the standards of this protocol. This verification guidance supplements the Reserve's Verification Program Manual and describes verification activities in the context of landfill gas destruction projects.

Verification bodies trained to verify landfill gas projects must conduct verifications to the standards of the following documents:

- Climate Action Reserve Program Manual
- Climate Action Reserve Verification Program Manual
- Climate Action Reserve Landfill Project Protocol

The Reserve's Program Manual, Verification Program Manual, and project protocols are designed to be compatible with each other and are available on the Reserve's website at <http://www.climateactionreserve.org>.

In cases where the Program Manual and/or Verification Program Manual differ from the guidance in this protocol, this protocol takes precedent.

Only ISO-accredited verification bodies trained by the Reserve for this project type are eligible to verify landfill project reports. Verification bodies approved under other project protocol types are not permitted to verify landfill projects. Information about verification body accreditation and Reserve project verification training can be found in the Verification Program Manual.

### 8.1 Standard of Verification

The Reserve's standard of verification for landfill projects is the Landfill Project Protocol (this document), the Reserve Program Manual, and the Verification Program Manual. To verify a landfill project developer's project report, verification bodies apply the guidance in the Verification Program Manual and this section of the protocol to the standards described in Section 2 through 7 of this protocol. Sections 2 through 7 provide eligibility rules, methods to calculate emission reductions, performance monitoring instructions and requirements, and procedures for reporting project information to the Reserve.

### 8.2 Monitoring Plan

The Monitoring Plan serves as the basis for verification bodies to confirm that the monitoring and reporting requirements in Section 6 and Section 7 have been met, and that consistent, rigorous monitoring and record-keeping is ongoing at the project site. Verification bodies shall confirm that the Monitoring Plan covers all aspects of monitoring and reporting contained in this protocol and specifies how data for all relevant parameters in Table 6.1 are collected and recorded.

### 8.3 Verifying Project Eligibility

Verification bodies must affirm a landfill project's eligibility according to the rules described in this protocol. The table below outlines the eligibility criteria for a landfill project. This table does not represent all criteria for determining eligibility comprehensively; verification bodies must also look to Section 3 and the verification items list in Table 8.2.

**Table 8.1.** Summary of Eligibility Criteria

Eligibility Rule	Eligibility Criteria	Frequency of Rule Application
Start Date	Projects must be submitted for listing within 6 months of the project start date	Once during first verification
Location	United States and its territories	Once during first verification
Performance Standard	Installation of a qualifying destruction device where not required by law (see Section 3.4.1 for other requirements)	Once during first verification
Legal Requirement Test	Signed Regulatory Attestation form and monitoring procedures that lay out procedures for ascertaining and demonstrating that the project passes the Legal Requirement Test	Every verification
Regulatory Compliance Test	Project must be in material compliance with all applicable laws	Every verification
Exclusions	<ul style="list-style-type: none"> <li>▪ Bioreactors</li> <li>▪ Landfills which re-circulate a liquid other than leachate in a controlled manner</li> <li>▪ Indirect emissions from the displacement of grid electricity or natural gas</li> </ul>	Every verification

## 8.4 Core Verification Activities

The Landfill Project Protocol provides explicit requirements and guidance for quantifying GHG reductions associated with the destruction of landfill methane. The Verification Program Manual describes the core verification activities that shall be performed by verification bodies for all project verifications. They are summarized below in the context of a landfill project, but verification bodies shall also follow the general guidance in the Verification Program Manual.

Verification is a risk assessment and data sampling effort designed to ensure that the risk of reporting error is assessed and addressed through appropriate sampling, testing, and review. The three core verification activities are:

1. Identifying emissions sources, sinks and reservoirs
2. Reviewing GHG management systems and estimation methodologies
3. Verifying emission reduction estimates

### Identifying emission sources, sinks, and reservoirs

The verification body reviews for completeness the sources, sinks, and reservoirs identified for a project, such as system energy use, fuel consumption, combustion and destruction from various qualifying and non-qualifying destruction devices, and soil oxidation.

### Reviewing GHG management systems and estimation methodologies

The verification body reviews and assesses the appropriateness of the methodologies and management systems that the landfill project uses to gather data on methane collected and destroyed and to calculate baseline and project emissions.

### Verifying emission reduction estimates

The verification body further investigates areas that have the greatest potential for material misstatements and then confirms whether or not material misstatements have occurred. This involves site visits to the project to ensure the systems on the ground correspond to and are consistent with data provided to the verification body. In addition, the verification body recalculates a representative sample of the performance or emissions data for comparison with data reported by the project developer in order to double-check the calculations of GHG emission reductions.

## 8.5 Landfill Project Verification Items

The following tables provide lists of items that a verification body needs to address while verifying a landfill project. The tables include references to the section in the protocol where requirements are further described. The table also identifies items for which a verification body is expected to apply professional judgment during the verification process. Verification bodies are expected to use their professional judgment to confirm that protocol requirements have been met in instances where the protocol does not provide (sufficiently) prescriptive guidance. For more information on the Reserve's verification process and professional judgment, please see the Verification Program Manual.

**Note: These tables shall not be viewed as a comprehensive list or plan for verification activities, but rather guidance on areas specific to landfill projects that must be addressed during verification.**

### 8.5.1 Project Eligibility and CRT Issuance

Table 8.2 lists the criteria for reasonable assurance with respect to eligibility and CRT issuance for landfill projects. These requirements determine if a project is eligible to register with the Reserve and/or have CRTs issued for the reporting period. If any one requirement is not met, either the project may be determined ineligible or the GHG reductions from the reporting period (or sub-set of the reporting period) may be ineligible for issuance of CRTs, as specified in Sections 2, 3, and 6.

**Table 8.2.** Eligibility Verification Items

Protocol Section	Eligibility Qualification Item	Apply Professional Judgment?
2.2	Verify that the project meets the definition of a landfill project and is properly defined per Section 2.2	No
4	Confirm all pre-project non-qualifying devices have been properly accounted for within project's GHG Assessment Boundary	No
4	Confirm all pre-project qualifying devices have been properly accounted for within project's GHG Assessment Boundary	
2.3	Verify ownership of the reductions by reviewing Attestation of Title	No
2.3	For direct use agreements between the project developer and the end user of the landfill gas (i.e. an industrial client purchasing the landfill gas from the project developer), verify that a legally binding mechanism is built into the agreement language to assure that the GHG offset credits will not be double counted	
3.2	Verify eligibility of project start date	No
3.2	Verify accuracy of project start date based on operational records	Yes
3.3	Verify that project is within its 10 year crediting period	No



Protocol Section	Eligibility Qualification Item	Apply Professional Judgment?
3.4.2	Confirm execution of the Regulatory Attestation form to demonstrate eligibility under the Legal Requirement Test	No
6	Verify that the project monitoring plan contains procedures for ascertaining and demonstrating that the project passes the Legal Requirement Test at all times	Yes
3.4.1	Verify that the project meets the appropriate Performance Standard Test for the project type per Section 3.4.1	No
3.4.2	Verify that the project activities comply with applicable laws by reviewing any instances of non-compliance provided by the project developer and performing a risk-based assessment to confirm the statements made by the project developer in the Regulatory Attestation form	Yes
6	Verify that monitoring meets the requirements of the protocol. If it does not, verify that a variance has been approved for monitoring variations.	No
6.2	Verify that all gas flow meters and methane analyzers adhered to the inspection, cleaning, and calibration schedule specified in the protocol. If they do not, verify that a variance has been approved for monitoring variations or that adjustments have been made to data per the protocol requirements	No
6	Verify that the landfill gas control system operated in a manner consistent with the design specifications	Yes
6	Verify that there is an individual responsible for managing and reporting GHG emissions, and that individual properly trained and qualified to perform this function	Yes
7.1	Verify that appropriate documents are created to support and/or substantiate activities related to GHG emission reporting activities, and that such documentation is retained appropriately	Yes
6.2	If any piece of equipment failed a calibration check, verify that data from that equipment was scaled according to the failed calibration procedure for the appropriate time period	No
6.3	If used, verify that data substitution methodology was properly applied	No
	If any variances were granted, verify that variance requirements were met and properly applied	Yes

### 8.5.2 Quantification of GHG Emission Reductions

Table 8.3 lists the items that verification bodies shall include in their risk assessment and recalculation of the project's GHG emission reductions. These quantification items inform any determination as to whether there are material and/or immaterial misstatements in the project's GHG emission reduction calculations. If there are material misstatements, the calculations must be revised before CRTs are issued.

**Table 8.3.** Quantification Verification Items

Protocol Section	Quantification Item	Apply Professional Judgment?
4	Verify that SSRs included in the GHG Assessment Boundary correspond to those required by the protocol and those represented in the project	No
5	Verify that the project developer correctly accounted for pre-project methane destruction in the baseline scenario	No
5	Verify that the project developer correctly monitored, quantified and aggregated the amount of methane collected from the landfill and	

Protocol Section	Quantification Item	Apply Professional Judgment?
	destroyed by the project landfill gas control system?	
5	Verify that the project developer correctly quantified and aggregated electricity use	Yes
5	Verify that the project developer correctly quantified and aggregated fossil fuel use	Yes
5	Verify that the project developer applied the correct emission factors for fossil fuel combustion and grid-delivered electricity	No
5	Verify that the project developer applied the correct methane destruction efficiencies	No
Appendix C	If the project developer used source test data in place of the default destruction efficiencies (Appendix C), verify accuracy and appropriateness of data and calculations	Yes

### 8.5.3 Risk Assessment

Verification bodies will review the following items in Table 8.4 to guide and prioritize their assessment of data used in determining eligibility and quantifying GHG emission reductions.

**Table 8.4.** Risk Assessment Verification Items

Protocol Section	Item that Informs Risk Assessment	Apply Professional Judgment?
6	Verify that the project monitoring plan is sufficiently rigorous to support the requirements of the protocol and proper operation of the project	Yes
6.2	Verify that the methane destruction equipment was operated and maintained according to manufacturer specifications	Yes
6	Verify that appropriate monitoring equipment is in place to meet the requirements of the protocol	No
6	Verify that the individual or team responsible for managing and reporting project activities are qualified to perform this function	Yes
6	Verify that appropriate training was provided to personnel assigned to greenhouse gas reporting duties	Yes
6	Verify that all contractors are qualified for managing and reporting greenhouse gas emissions if relied upon by the project developer. Verify that there is internal oversight to assure the quality of the contractor's work	Yes
7.2	Verify that all required records have been retained by the project developer	No

### 8.6 Completing Verification

The Verification Program Manual provides detailed information and instructions for verification bodies to finalize the verification process. It describes completing a Verification Report, preparing a Verification Opinion, submitting the necessary documents to the Reserve, and notifying the Reserve of the project's verified status.

## 9 Glossary of Terms

Accredited verification body	A verification firm approved by the Climate Action Reserve to provide verification services for project developers.
Additionality	Landfill management practices that are above and beyond business-as-usual operation, exceed the baseline characterization, and are not mandated by regulation.
Anaerobic	Pertaining to or caused by the absence of oxygen.
Anthropogenic emissions	GHG emissions resultant from human activity that are considered to be an unnatural component of the Carbon Cycle (i.e. fossil fuel destruction, de-forestation, etc.).
Biogenic CO <sub>2</sub> emissions	CO <sub>2</sub> emissions resulting from the destruction and/or aerobic decomposition of organic matter. Biogenic emissions are considered to be a natural part of the Carbon Cycle, as opposed to anthropogenic emissions.
Bioreactor	Any landfill which: <ol style="list-style-type: none"> <li>a. Meets the EPA definition of a bioreactor: “a MSW landfill or portion of a MSW landfill where any liquid other than leachate (leachate includes landfill gas condensate) is added in a controlled fashion into the waste mass (often in combination with recirculating leachate) to reach a minimum average moisture content of at least 40 percent by weight to accelerate or enhance the anaerobic (without oxygen) biodegradation of the waste.”<sup>30</sup></li> <li>b. Has been designated by local, state, or federal regulators as a bioreactor.</li> <li>c. Has received grants or funding to operate as a bioreactor.</li> </ol>
Carbon dioxide (CO <sub>2</sub> )	The most common of the six primary greenhouse gases, consisting of a single carbon atom and two oxygen atoms.
Closed landfill	A landfill that has ceased waste acceptance, and has submitted a closure report to EPA or the state indicating that it will no longer accept waste.
CO <sub>2</sub> equivalent (CO <sub>2</sub> e)	The quantity of a given GHG multiplied by its total global warming potential. This is the standard unit for comparing the degree of warming which can be caused by different GHGs.
Direct emissions	Greenhouse gas emissions from sources that are owned or controlled by the reporting entity.
Eligible landfill	An “eligible landfill” is a landfill that: <ol style="list-style-type: none"> <li>1. Is not subject to regulations or other legal requirements requiring the destruction of methane gas</li> <li>2. Is not a bioreactor</li> <li>3. Does not add any liquid other than leachate into the waste mass in a controlled manner</li> </ol>

<sup>30</sup> 40 CFR 63.1990 and 40 CFR 258.28a.

Emission factor (EF)	A unique value for determining an amount of a greenhouse gas emitted for a given quantity of activity data (e.g. metric tons of carbon dioxide emitted per barrel of fossil fuel burned).
Emission guidelines (EG)	Guidelines for State regulatory plans that have been developed by the U.S. EPA. For landfills, emission guidelines are codified in 40 CFR 60 Subpart Cc.
Flare	A destruction device that uses an open flame to burn combustible gases with combustion air provided by uncontrolled ambient air around the flame.
Fossil fuel	A fuel, such as coal, oil, and natural gas, produced by the decomposition of ancient (fossilized) plants and animals.
Greenhouse gas (GHG)	Carbon dioxide (CO <sub>2</sub> ), methane (CH <sub>4</sub> ), nitrous oxide (N <sub>2</sub> O), sulfur hexafluoride (SF <sub>6</sub> ), hydrofluorocarbons (HFCs), or perfluorocarbons (PFCs).
Global warming potential (GWP)	The ratio of radiative forcing (degree of warming to the atmosphere) that would result from the emission of one unit of a given GHG compared to one unit of CO <sub>2</sub> .
Indirect emissions	Emissions that are a consequence of the actions of a reporting entity, but are produced by sources owned or controlled by another entity.
Landfill	A defined area of land or excavation that receives or has previously received waste that may include household waste, commercial solid waste, non-hazardous sludge and industrial solid waste.
Landfill gas (LFG)	Gas resulting from the decomposition of wastes placed in a landfill. Typically, landfill gas contains methane, carbon dioxide and other trace organic and inert gases.
Landfill gas project	Installation of infrastructure that in operating causes a decrease in GHG emissions through destruction of the methane component of landfill gas.
Metric ton (MT) or "tonne"	A common international measurement for the quantity of GHG emissions, equivalent to about 2204.6 pounds or 1.1 short tons.
Methane (CH <sub>4</sub> )	A potent GHG with a GWP of 21, consisting of a single carbon atom and four hydrogen atoms.
MMBtu	One million British thermal units.
Mobile combustion	Emissions from the transportation of materials, products, waste, and employees resulting from the combustion of fuels in company owned or controlled mobile combustion sources (e.g. cars, trucks, tractors, dozers, etc.).
National Emission Standards for Hazardous Air Pollutants (NESHAP)	Federal emission control standards codified in 40 CFR 63. Subpart AAAA of Part 63 prescribes emission limitations for MSW landfills.

New Source Performance Standards (NSPS)	Federal emission control standards codified in 40 CFR 60. Subpart WWW of Part 60 prescribes emission limitations for MSW landfills.
Non-methane organic compounds (NMOC)	Non-methane organic compounds as measured according to the provisions of 40 CFR 60.754.
Non-qualifying destruction device	A passive flare or other combustion system that results in the destruction of methane, but which cannot serve as the primary destruction device for a methane destruction project under this protocol.
Nitrous oxide (N <sub>2</sub> O)	A GHG consisting of two nitrogen atoms and a single oxygen atom.
Project baseline	A business-as-usual GHG emission assessment against which GHG emission reductions from a specific GHG reduction activity are measured.
Project developer	An entity that undertakes a project activity, as identified in the Landfill Project Protocol. A project developer may be an independent third party or the landfill operating entity.
Qualifying destruction device	A utility flare, enclosed flare, engine, boiler, pipeline, vehicle, or fuel cell which can serve as the primary destruction device for a methane destruction project under this protocol.
Reporting period	Specific time period of project operation for which the project developer has calculated and reported emission reductions and is seeking verification and issuance of credits. The reporting period must be no longer than 12 months.
Resource Conservation and Recovery Act (RCRA)	Federal legislation under which solid and hazardous waste disposal facilities are regulated.
Stationary combustion source	A stationary source of emissions from the production of electricity, heat, or steam, resulting from combustion of fuels in boilers, furnaces, turbines, kilns, and other facility equipment.
Verification	The process used to ensure that a given participant's GHG emissions or emission reductions have met the minimum quality standard and complied with the Reserve's procedures and protocols for calculating and reporting GHG emissions and emission reductions.
Verification body	An ISO-accredited and Reserve-approved firm that is able to render a verification opinion and provide verification services for operators subject to reporting under this protocol.
Verification cycle	The Reserve requires verification of landfill projects annually, but does not require verifications to be completed on specific dates. Project developers select the reporting period to be verified. Thus, each project has a unique verification cycle that begins the first time a project is verified, occurs at least annually, and ends once the crediting period expires or the project is no longer eligible, whichever happens first.

## 10References

California Climate Action Registry, General Reporting Protocol Version 2.2, March 2007.

California Air Resources Board, Landfill Methane Control Measure web page  
<http://www.arb.ca.gov/cc/ccea/landfills/landfills.htm>.

GE AES Greenhouse Gas Services, Landfill Gas Methodology, Version 1.0 (July 2007).

Intergovernmental Panel on Climate Change, Good Practice Guidance and Uncertainty Management in National Greenhouse Gas Inventories (2001).

Intergovernmental Panel on Climate Change, IPCC Guidelines for National Greenhouse Gas Inventories, Chapter 10: Emissions from Livestock and Landfill (2006).

International Organization for Standardization, ISO 14064 Greenhouses Gases Part 2, "Specification with Guidance at the Project Level for Quantification, Monitoring and Reporting of Greenhouse Gas Emissions Reductions or Removal Enhancements", First Edition 2006-03-01.

International Organization for Standardization, ISO 14064 Greenhouses Gases Part 3, "Specification With Guidance for the Validation and Verification of Greenhouse Gas Assertions", First Edition 2006-03-01.

Methane to Markets Partnership Landfills Subcommittee. 2007 Methane To Markets Partnership Expo, Preliminary Assessment For Landfill Methane Partnership Opportunities.

Nicholas Institute for Environmental Policy Solutions. "Harnessing Farms and Forests in the Low-Carbon Economy How to Create, Measure, and Verify Greenhouse Gas Offsets", Duke University Press, Durham & London, 2007.

Regional Greenhouse Gas Initiative, Draft Model Rule (January 2007).

United Nations Framework Convention on Climate Change (UNFCCC), Revisions to the Approved Consolidated Baseline and Monitoring Methodology ACM0001, "Consolidated baseline methodology for landfill gas project activities," Clean Development Mechanism, Versions 06, Sectoral Scope 13 (July 2007).

United Nations Framework Convention on Climate Change (UNFCCC), Revisions to the Approved Consolidated Baseline and Monitoring Methodology ACM0001, "Consolidated baseline methodology for landfill gas project activities," Clean Development Mechanism, Versions 07, Sectoral Scope 13 (November 2007).

United Nations Framework Convention on Climate Change (UNFCCC), Approved Baseline and Monitoring Methodology AM0053, "Biogenic methane injection to a natural gas distribution grid" Clean Development Mechanism, Version 01, Sectoral Scopes 01 and 05 (2007).

U.S. Department of Energy 1605(b) Technical Guidelines for Voluntary Reporting of Greenhouse Gas Program.

U.S. Environmental Protection Agency, Inventory of U.S. Greenhouse Gas Emissions and Sinks: 1990-2005, EPA-430-R-07-002 (April 2007).

U.S. Environmental Protection Agency - Climate Leaders, Draft Offset Protocol – Landfill Methane Collection and Combustion, (October 2006).

World Resource Institute and World Business Counsel for Sustainable Development, Greenhouse Gas Protocol for Project Accounting (November 2005).

## Appendix A Development of the Performance Standard Threshold

The primary data source for the performance standard threshold is the database of nearly 2,400 landfills in the United States developed and maintained by the U.S. EPA's Landfill Methane Outreach Program (LMOP).<sup>31</sup> This database does not represent all U.S. landfills, but rather a subset of all landfills that have been identified as having current projects or where potential opportunities exist. If landfill gas collection and combustion projects at regulated landfills do not pass the Reserve's Legal Requirement Test, they are not eligible as greenhouse gas offset projects. Therefore, detailed data on regulated landfills need not be included in this analysis.

Landfill summary information is provided in Tables A.1 and A.2 with a focus on those landfills not currently subject to the New Source Performance Standards and Emission Guidelines for existing sources (NSPS/EG) promulgated in March 1996.

For the purposes of this analysis, we excluded all landfills that were closed prior to 2001, as their methane production has already dropped off significantly. Of the remaining 1,866 landfills in the U.S., the analysis revealed that an estimated 697 are subject to NSPS/EG, and 1,169 are not subject to NSPS/EG (not required to combust landfill gas under federal regulations). Of the non-NSPS/EG landfills, 261 (22.33%) currently have gas collection and destruction projects, of which 166 (14.20%) are flare only, 67 (5.73%) are electricity projects, and 28 (2.40%) are gas projects.

Focusing on the non-NSPS/EG landfill operations, the Reserve has developed an estimated range for market penetration of voluntary landfill gas collection and control projects at unregulated landfills. As the LMOP database does not contain information on state and local regulations, ordinances or permitting requirements that may affect landfill operations, it is necessary to make assumptions regarding additional regulatory influence on landfill operations. To estimate an upper bound for market penetration, it is assumed that all 261 non-NSPS/EG landfills with gas collection and control (see Table A.2) are *not* required to collect and control gas. Under this assumption, 261 out of 1,169 landfills have implemented voluntary landfill gas projects, equating to a market penetration of 22.3 percent. To construct a lower bound, it is assumed that all 166 non-NSPS/EG landfills with flares (see Table A.2) are required by state and local regulations, ordinances or permitting requirements to have the flares installed. This assumption is based on the observation that there is generally no incentive for a landfill to install a flare absent requirements imposed by regulations, ordinances or permitting requirements. Therefore it is likely that many non-NSPS/EG landfills with flares are required by state or local regulations, ordinances or permitting requirements to combust landfill gas. By assuming all 166 non-NSPS/EG landfills with flares are required to combust landfill gas, a lower bound for market penetration can be estimated. Under this assumption, 95 out of 1,003 unregulated landfills have implemented voluntary landfill gas projects, resulting in a market penetration of 9.5 percent.

---

<sup>31</sup> LMOP is a voluntary partnership program that was created to reduce methane emissions from landfills by encouraging the use of landfill gas for energy. LMOP tracks whether or not specific landfills are required to reduce landfill gas emissions under the New Source Performance Standards and Emission Guidelines for Municipal Solid Waste Landfills (NSPS/EG). Because LMOP is not a regulatory program, it cannot make an official EPA designation regarding any landfill's NSPS/EG status. Information relating to NSPS/EG was obtained by voluntary submittal and is subject to change over time. Therefore, LMOP can not guarantee the validity of this information.



**Table A.1.** Summary of Information on U.S. landfills (NSPS/EG and Non-NSPS/EG)

	Landfills	Percent of Landfills	Number w/ Gas Collection and Control	Percent w/ Gas Collection and Control
<b>Landfills in Analysis</b>				
NSPS/EG	697	37.35	697	100
Non-NSPS/EG	1169	62.65	261	22.33
Subtotal	1866	100	958	51.34
<b>Landfills Excluded from Analysis</b>	518			
<b>Total U.S. Landfills</b>	2384			

**Table A.2.** Summary of Non-NSPS/EG Landfills under Assumption that Flare Only Landfills Are Already Regulated

Non-NSPS/EG Landfills	Number of Landfills	Percent of Unregulated Landfills – Flares Included	Percent of Unregulated Landfills – Flares Excluded
Flare Only	166	14.2%	Excluded
Electricity	67	5.7%	6.7%
Gas Projects	28	2.4%	2.8%
Subtotal	261	22.3%	9.5%
No Gas Collection and Control	908	77.7%	90.5%
Total	1169	100.0%	100.0%
<b>Estimated Market Penetration of Gas Collection and Control Projects into unregulated landfills</b>		<b>22.3%</b>	<b>9.5%</b>

## Appendix B Development of the NMOC Emissions Threshold

### Purpose

For the specific case in which a landfill gas control system is required to treat landfill gas for NMOC in order to comply with a regulation, ordinance, or permitting condition, but destruction of the landfill gas is not the only compliance mechanism available to the landfill operator, the Reserve has developed an NMOC emissions threshold whereby the eligibility of a project can be determined. If a landfill gas control system is required to treat landfill gas for NMOC and the total mass flow of NMOC for the landfill gas control system is less than the threshold (measured in pounds NMOC per month), then the landfill gas control system is eligible as a GHG reduction project under this protocol. If a landfill gas control system is required to treat landfill gas for NMOC and the total mass flow of NMOC for the landfill gas control system is greater than the threshold, then the landfill gas control system is *not* eligible as a GHG reduction project under this protocol. The Reserve has established two separate NMOC thresholds for 1) landfills in air management districts or regions that permit the use of open flares, and 2) landfills in air management districts or regions that permit *only* enclosed flares.

The NMOC mass flow at a given landfill is one of many factors including the quantity, age and composition of the waste, and the environmental conditions at the landfill.

### Data

The primary data source for the threshold analysis is a series of empirical capital cost and monthly operating cost data supplied to the Reserve from fourteen landfills with experience using carbon adsorption to treat varying levels of NMOC. In addition, the Reserve obtained quotes for the purchase, installation, and operation of both open (candlestick or utility-type) flares and enclosed flares from a number of prominent vendors and engineering firms.<sup>32</sup>

### Summary

The analysis below reveals that an estimated NMOC<sup>33</sup> mass flow threshold of 1,775 lbs NMOC/month is appropriate for the performance standard in areas where open flares may be used, and a threshold of 2,575 is appropriate for the performance standard in areas where only enclosed flares may be installed. This analysis was performed based on the empirical data and estimates obtained for flare and carbon adsorption systems with capacities of 40 to 1,000 cubic feet per minute (CFM) of landfill gas and an operational life of ten years. While the upfront costs for a flare system are relatively high (approximately \$200,000 for an open flare and \$290,000 for an enclosed flare), the costs for installing a carbon adsorption system are significantly lower (typically below \$20,000). Both systems require comparable operation and maintenance costs, but the carbon adsorption system has an additional cost associated with the replacement and disposal of activated carbon. As NMOC levels increase, additional carbon is required, and therefore costs increase as well. The overall cost of a carbon adsorption system is therefore highly dependent on the mass flow of NMOC, as the carbon must be replaced once saturated. Thus, determining the NMOC threshold is a matter of identifying the NMOC level that requires carbon costs equal to or greater than the additional cost of the flare. The analysis shows that the installation of an open flare system for NMOC control is more cost effective than carbon

<sup>32</sup> Due to proprietary confidentiality, the landfill operations and service providers who provided operational data and cost quotes will remain anonymous.

<sup>33</sup> NMOC concentration (ppmv) normalized to hexane.

adsorption if the measured landfill gas flow rate (CFM) and NMOC concentration (ppmv) result in a total mass flow of 1,775 lbs of NMOC per month or greater. For an enclosed flare, this break-even point is 2,575 lbs of NMOC per month. Above these levels, costs of carbon adsorption systems, particularly the monthly carbon replacement costs, become cost prohibitive relative to flare systems even in light of the high capital costs of flares.

### Methodology

In order to carry out this analysis, the Reserve required reliable cost information for both carbon adsorption and open and enclosed flare systems. These data were obtained by soliciting quotes from the technical sales departments of well known flare vendors, and from historical data at sites utilizing carbon adsorption. Multiple quotes were obtained for each flare system type to accurately reflect the costs of open and enclosed systems scaled to 1,000 CFM. These quotes allowed the Reserve to calculate a net present value (NPV) cost of the purchase, installation, transportation, and basic instrumentation of the flare systems and purchase, installation, and carbon replacement costs of carbon systems over a ten-year operational life. This analysis applied an 8% discount rate. A summary of these costs is provided in Table B.1 and Table B.2.

The Reserve used these data and relationships to calculate the NMOC mass flow at which an open or enclosed landfill flare becomes more cost effective than a carbon adsorption system. This was done by first calculating the NPV cost to treat one pound of NMOC per month for ten years in each of the carbon systems analyzed, and then determining how many pounds of NMOC could be treated at that cost for the NPV cost of the flares. This value represents the NMOC threshold: the NMOC mass flow at which a landfill operator would be indifferent as to which technology was installed.

Total NPV costs for the enclosed and open flares were calculated as follows:

$Cost_{Flare,j} = \frac{Capital_{Flare,j}}{(1 + 0.08)^t}$											
<i>Where,</i>											
<table style="width: 100%; border: none;"> <tr> <td style="padding: 5px 10px;"> <table style="width: 100%; border: none;"> <tr> <td style="padding: 5px 10px;"><math>Cost_{Flare,j}</math></td> <td style="padding: 5px 10px;">= NPV of total costs (excluding O&amp;M) of flare <i>j</i></td> <td style="padding: 5px 10px; text-align: right;">\$</td> </tr> <tr> <td style="padding: 5px 10px;"><math>Capital_{Flare,j}</math></td> <td style="padding: 5px 10px;">= Capital cost of flare purchase, transportation, installation, and basic instrumentation, for flare <i>j</i></td> <td style="padding: 5px 10px; text-align: right;">\$</td> </tr> <tr> <td style="padding: 5px 10px;"><math>t</math></td> <td style="padding: 5px 10px;">= Year in which expense was accrued</td> <td></td> </tr> </table> </td> <td style="padding: 5px 10px; text-align: right; vertical-align: top;"><u>Units</u></td> </tr> </table>	<table style="width: 100%; border: none;"> <tr> <td style="padding: 5px 10px;"><math>Cost_{Flare,j}</math></td> <td style="padding: 5px 10px;">= NPV of total costs (excluding O&amp;M) of flare <i>j</i></td> <td style="padding: 5px 10px; text-align: right;">\$</td> </tr> <tr> <td style="padding: 5px 10px;"><math>Capital_{Flare,j}</math></td> <td style="padding: 5px 10px;">= Capital cost of flare purchase, transportation, installation, and basic instrumentation, for flare <i>j</i></td> <td style="padding: 5px 10px; text-align: right;">\$</td> </tr> <tr> <td style="padding: 5px 10px;"><math>t</math></td> <td style="padding: 5px 10px;">= Year in which expense was accrued</td> <td></td> </tr> </table>	$Cost_{Flare,j}$	= NPV of total costs (excluding O&M) of flare <i>j</i>	\$	$Capital_{Flare,j}$	= Capital cost of flare purchase, transportation, installation, and basic instrumentation, for flare <i>j</i>	\$	$t$	= Year in which expense was accrued		<u>Units</u>
<table style="width: 100%; border: none;"> <tr> <td style="padding: 5px 10px;"><math>Cost_{Flare,j}</math></td> <td style="padding: 5px 10px;">= NPV of total costs (excluding O&amp;M) of flare <i>j</i></td> <td style="padding: 5px 10px; text-align: right;">\$</td> </tr> <tr> <td style="padding: 5px 10px;"><math>Capital_{Flare,j}</math></td> <td style="padding: 5px 10px;">= Capital cost of flare purchase, transportation, installation, and basic instrumentation, for flare <i>j</i></td> <td style="padding: 5px 10px; text-align: right;">\$</td> </tr> <tr> <td style="padding: 5px 10px;"><math>t</math></td> <td style="padding: 5px 10px;">= Year in which expense was accrued</td> <td></td> </tr> </table>	$Cost_{Flare,j}$	= NPV of total costs (excluding O&M) of flare <i>j</i>	\$	$Capital_{Flare,j}$	= Capital cost of flare purchase, transportation, installation, and basic instrumentation, for flare <i>j</i>	\$	$t$	= Year in which expense was accrued		<u>Units</u>	
$Cost_{Flare,j}$	= NPV of total costs (excluding O&M) of flare <i>j</i>	\$									
$Capital_{Flare,j}$	= Capital cost of flare purchase, transportation, installation, and basic instrumentation, for flare <i>j</i>	\$									
$t$	= Year in which expense was accrued										

Total NPV cost for the carbon adsorption system was calculated as follows:

$$Cost_{Carbon,i} = Capital_{Carbon} + \sum_{t=1}^{10} \frac{(Carbon_{month,i} \times 12)}{(1 + 0.08)^t}$$

Where, Units

$Cost_{Carbon,i}$	= NPV of total costs (excluding non-carbon related O&M) of carbon system $i$	\$
$Capital_{Carbon}$	= Capital cost purchase and installation of carbon system $i$	\$
$Carbon_{month,i}$	= Monthly cost of purchasing, transporting, and disposing of carbon at carbon system $i$	\$/month
12	= Months per year	month
0.08	= Annual discount rate	
$t$	= Year in which expense was accrued, 1 through 10	

Using the total NPV cost of each carbon adsorption system, the Reserve was able to establish the ten-year NPV cost of treating one pound of NMOC per month by dividing  $Cost_{Carbon,i}$  by the NMOC mass flow associated with that system.

$$NMOCCost_{Carbon,i} = \frac{Cost_{Carbon,i}}{NMOC_{month,i}}$$

Where, Units

$NMOCCost_{Carbon,i}$	= NPV of treating 1 pound of NMOC per month for 10 years, using carbon system $i$	\$/lb
$NMOC_{month,i}$	= Pounds per month of NMOC treated by carbon system $i$	lb/month

Next, by dividing the cost of the flare, the Reserve arrived at the break-even amount of carbon that could be treated for the same cost using either a flare or carbon system. This analysis was run separately for both the open and enclosed flares.

$$NMOC_{Threshold} = \frac{Cost_{flare,j}}{NMOCCost_{Carbon,i}}$$

Where, Units

$NMOC_{Threshold}$	= Pounds of NMOC that can be treated for the same cost using either carbon system $i$ or flare system $j$	lb/month
--------------------	---	----------

The resulting NMOC threshold at each carbon facility was averaged to obtain a single NMOC threshold for open flare facilities, and a separate one for enclosed flare facilities.

## Results

Quotes for both open and enclosed flares obtained by the Reserve and used in this analysis are provided below in Table B.1.

**Table B.1.** Quotes from Vendors/Engineering Firms for the Cost of Flare, Transportation, Installation, and Basic Instrumentation

Open Flare Quote	Bid	Enclosed Flare Quote	Bid
1	\$116,500	1	\$185,000
2	\$150,000	2	\$335,000
3	\$275,000	3	\$215,000
4	\$137,000	4	\$320,000
5	\$157,500	5	\$195,000
6	\$265,000	6	\$415,000
7	\$310,000	7	\$350,000
8	\$190,000		
Average	\$200,125	Average	\$287,857

The analysis included in this table incorporates installation costs for open flares of \$200,000 and for enclosed flares of \$290,000. These values represent an average cost of purchase, transportation, installation, and basic instrumentation for open and enclosed flares. Costs for well fields and blower systems are expected to be comparable for both carbon systems and flare systems and are therefore not included in the analysis.

A summary of the cost data for carbon systems used in this analysis is provided in Table B.2. This table also provides the results of the analysis comparing each of the site's costs to those necessary to treat the NMOC using an open or enclosed flare.

**Table B.2.** Summary of Install and Monthly Carbon Costs for Carbon Adsorption Systems at 14 Landfills

Site	Capital Cost (\$)	Monthly Costs (\$)	Total 10 yr NPV (\$)	NMOC Rate (lb/mo)	10 yr NPV NMOC (\$/lb/mo)	NMOC Threshold (Open flare)	NMOC Threshold (Enclosed flare)
1	\$7,200	\$710	\$64,343	1,376	\$47	4,277	6,203
2	\$2,400	\$1,281	\$105,547	1,649	\$64	3,124	4,530
3	\$9,112	\$1,702	\$146,155	465	\$315	635	922
4	\$12,000	\$770	\$74,001	953	\$78	2,574	3,734
5	\$15,120	\$3,915	\$330,360	494	\$669	299	434
6	\$2,400	\$1,300	\$107,077	362	\$296	676	981
7	\$0	\$1,386	\$111,602	125	\$893	224	325
8	\$1,200	\$265	\$22,538	65	\$347	575	835
9	\$21,000	\$680	\$75,754	199	\$381	524	760
10	\$6,550	\$377	\$36,880	1,229	\$30	6,665	9,665
11	\$12,000	\$2,735	\$232,198	3,736	\$62	3,217	4,666
12	\$800	\$1,686	\$136,594	729	\$187	1,067	1,548
13	\$2,400	\$2,074	\$169,414	87	\$1,937	103	150
14	\$2,400	\$1,975	\$161,455	716	\$226	886	1,286
<b>Average</b>						<b>1,775</b>	<b>2,574</b>

As demonstrated above, the Reserve established an NMOC threshold of 1,775 lbs of NMOC per month at sites where open flares may be permitted, and 2,575 lbs of NMOC per month at sites where only enclosed flares may be installed.

Landfills for which the NMOC threshold applies, and which fall below the applicable threshold, are required to test for and calculate NMOC mass flow rates on an annual basis. If a test indicates a value above the applicable threshold, the landfill must commence quarterly NMOC analyses. Upon registering two consecutive quarterly NMOC tests above the applicable threshold, the landfill will be deemed to fail the NMOC threshold test and will be ineligible per the performance standard.

## Appendix C Emission Factor Tables

**Table C.1.** CO<sub>2</sub> Emission Factors for Fossil Fuel Use

Fuel Type	Heat Content	Carbon Content (Per Unit Energy)	Fraction Oxidized	CO <sub>2</sub> Emission Factor (Per Unit Energy)	CO <sub>2</sub> Emission Factor (Per Unit Mass or Volume)
<b>Coal and Coke</b>	<b>MMBtu / Short ton</b>	<b>kg C / MMBtu</b>		<b>kg CO<sub>2</sub> / MMBtu</b>	<b>kg CO<sub>2</sub> / Short ton</b>
Anthracite Coal	25.09	28.26	1.00	103.62	2,599.83
Bituminous Coal	24.93	25.49	1.00	93.46	2,330.04
Sub-bituminous Coal	17.25	26.48	1.00	97.09	1,674.86
Lignite	14.21	26.30	1.00	96.43	1,370.32
Unspecified (Residential/ Commercial)	22.05	26.00	1.00	95.33	2,102.29
Unspecified (Industrial Coking)	26.27	25.56	1.00	93.72	2,462.12
Unspecified (Other Industrial)	22.05	25.63	1.00	93.98	2,072.19
Unspecified (Electric Utility)	19.95	25.76	1.00	94.45	1,884.53
Coke	24.80	31.00	1.00	113.67	2,818.93
<b>Natural Gas (By Heat Content)</b>	<b>Btu / Standard cubic foot</b>	<b>kg C / MMBtu</b>		<b>kg CO<sub>2</sub> / MMBtu</b>	<b>kg CO<sub>2</sub> / Standard cub. ft.</b>
975 to 1,000 Btu / Std cubic foot	975 – 1,000	14.73	1.00	54.01	Varies
1,000 to 1,025 Btu / Std cubic foot	1,000 – 1,025	14.43	1.00	52.91	Varies
1,025 to 1,050 Btu / Std cubic foot	1,025 – 1,050	14.47	1.00	53.06	Varies
1,050 to 1,075 Btu / Std cubic foot	1,050 – 1,075	14.58	1.00	53.46	Varies
1,075 to 1,100 Btu / Std cubic foot	1,075 – 1,100	14.65	1.00	53.72	Varies
Greater than 1,100 Btu / Std cubic foot	> 1,100	14.92	1.00	54.71	Varies
Weighted U.S. Average	1,029	14.47	1.00	53.06	0.0546
<b>Petroleum Products</b>	<b>MMBtu / Barrel</b>	<b>kg C / MMBtu</b>		<b>kg CO<sub>2</sub> / MMBtu</b>	<b>kg CO<sub>2</sub> / gallon</b>
Asphalt & Road Oil	6.636	20.62	1.00	75.61	11.95
Aviation Gasoline	5.048	18.87	1.00	69.19	8.32
Distillate Fuel Oil (#1, 2 & 4)	5.825	19.95	1.00	73.15	10.15
Jet Fuel	5.670	19.33	1.00	70.88	9.57
Kerosene	5.670	19.72	1.00	72.31	9.76
LPG (average for fuel use)	3.849	17.23	1.00	63.16	5.79
Propane	3.824	17.20	1.00	63.07	5.74
Ethane	2.916	16.25	1.00	59.58	4.14
Isobutene	4.162	17.75	1.00	65.08	6.45
n-Butane	4.328	17.72	1.00	64.97	6.70
Lubricants	6.065	20.24	1.00	74.21	10.72
Motor Gasoline	5.218	19.33	1.00	70.88	8.81
Residual Fuel Oil (#5 & 6)	6.287	21.49	1.00	78.80	11.80
Crude Oil	5.800	20.33	1.00	74.54	10.29
Naphtha (<401 deg. F)	5.248	18.14	1.00	66.51	8.31
Natural Gasoline	4.620	18.24	1.00	66.88	7.36
Other Oil (>401 deg. F)	5.825	19.95	1.00	73.15	10.15
Pentanes Plus	4.620	18.24	1.00	66.88	7.36
Petrochemical Feedstocks	5.428	19.37	1.00	71.02	9.18
Petroleum Coke	6.024	27.85	1.00	102.12	14.65
Still Gas	6.000	17.51	1.00	64.20	9.17
Special Naphtha	5.248	19.86	1.00	72.82	9.10
Unfinished Oils	5.825	20.33	1.00	74.54	10.34
Waxes	5.537	19.81	1.00	72.64	9.58

Source: EPA Climate Leaders, Stationary Combustion Guidance (2007), Table B-2 except:

Default CO<sub>2</sub> emission factors (per unit energy) are calculated as: Carbon Content × Fraction Oxidized × 44/12.

Default CO<sub>2</sub> emission factors (per unit mass or volume) are calculated as: Heat Content x Carbon Content x Fraction Oxidized x 44/12x Conversion Factor (if applicable). Heat content factors are based on higher heating values (HHV).

**Table C.2. CO<sub>2</sub> Electricity Emission Factors**

eGRID subregion acronym	eGRID subregion name	Annual output emission rates	
		(lb CO <sub>2</sub> /MWh)	(metric ton CO <sub>2</sub> /MWh)*
AKGD	ASCC Alaska Grid	1,232.36	0.559
AKMS	ASCC Miscellaneous	498.86	0.226
AZNM	WECC Southwest	1,311.05	0.595
CAMX	WECC California	724.12	0.328
ERCT	ERCOT All	1,324.35	0.601
FRCC	FRCC All	1,318.57	0.598
HIMS	HICC Miscellaneous	1,514.92	0.687
HIOA	HICC Oahu	1,811.98	0.822
MROE	MRO East	1,834.72	0.832
MROW	MRO West	1,821.84	0.826
NEWE	NPCC New England	927.68	0.421
NWPP	WECC Northwest	902.24	0.409
NYCW	NPCC NYC/Westchester	815.45	0.370
NYLI	NPCC Long Island	1,536.80	0.697
NYUP	NPCC Upstate NY	720.80	0.327
RFCE	RFC East	1,139.07	0.517
RFCM	RFC Michigan	1,563.28	0.709
RFCW	RFC West	1,537.82	0.698
RMPA	WECC Rockies	1,883.08	0.854
SPNO	SPP North	1,960.94	0.889
SPSO	SPP South	1,658.14	0.752
SRMV	SERC Mississippi Valley	1,019.74	0.463
SRMW	SERC Midwest	1,830.51	0.830
SRSO	SERC South	1,489.54	0.676
SRTV	SERC Tennessee Valley	1,510.44	0.685
SRVC	SERC Virginia/Carolina	1,134.88	0.515

Source: U.S. EPA eGRID2007, Version 1.1 Year 2005 GHG Annual Output Emission Rates (December 2008).

\* Converted from lbs CO<sub>2</sub>/ MWh to metric tons CO<sub>2</sub>/MWH using conversion factor 1 metric ton = 2,204.62 lbs.



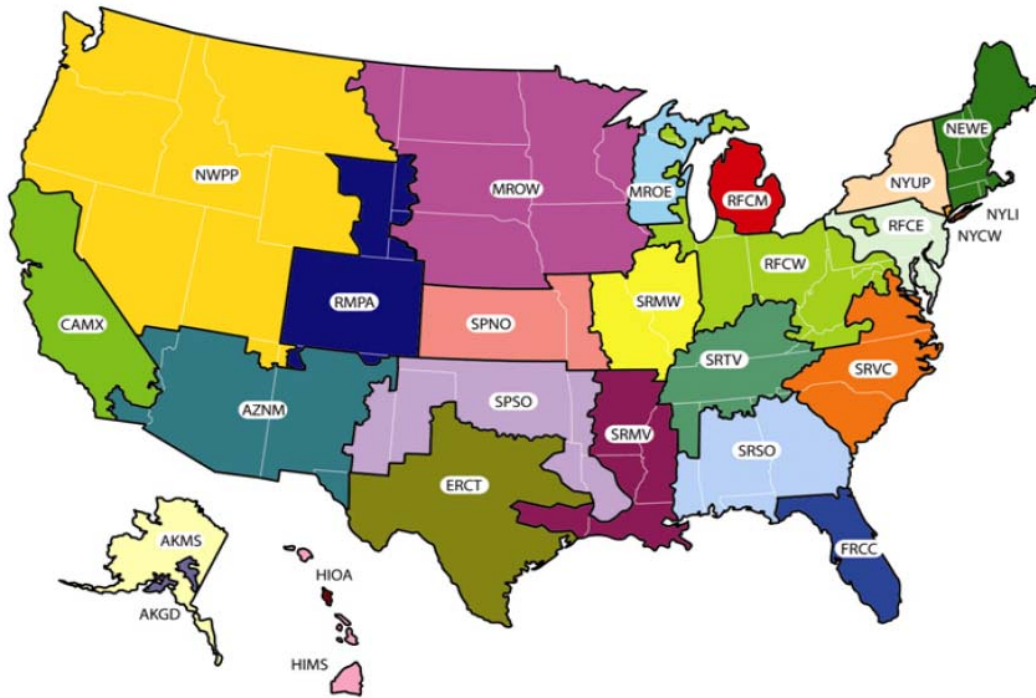

Figure C.1. Map of eGRID2007 Subregions

### Destruction Efficiencies for Combustion Devices

If available, the official source tested methane destruction efficiency shall be used in place of the default methane destruction efficiency. Project developers have the option to use either the default methane destruction efficiencies provided, or the site specific methane destruction efficiencies as provided by a state or local agency accredited source test service provider, for each of the combustion devices used in the project, performed on an annual basis.

**Table C.3.** Default Destruction Efficiencies for Combustion Devices

Destruction Device	Destruction Efficiency
Open Flare	0.96
Enclosed Flare	0.995
Lean-burn Internal Combustion Engine	0.936
Rich-burn Internal Combustion Engine	0.995
Boiler	0.98
Microturbine or large gas turbine	0.995
Upgrade and use of gas as CNG/LNG fuel	0.95
Upgrade and injection into natural gas pipeline	0.98**

Source: The default destruction efficiencies for enclosed flares and electricity generation devices are based on a preliminary set of actual source test data provided by the Bay Area Air Quality Management District. The default destruction efficiency values are the lesser of the twenty fifth percentile of the data provided or 0.995. These default destruction efficiencies may be updated as more source test data is made available to the Reserve.

\*\* The Revised 1996 IPCC Guidelines for National Greenhouse Gas Inventories gives a standard value for the fraction of carbon oxidized for gas destroyed of 99.5% (Reference Manual, Table 1.6, page 1.29). It also gives a value for emissions from processing, transmission and distribution of gas which would be a very conservative estimate for losses in the pipeline and for leakage at the end user (Reference Manual, Table 1.58, page 1.121). These emissions are given as 118,000kgCH<sub>4</sub>/PJ on the basis of gas consumption, which is 0.6%. Leakage in the residential and commercial sectors is stated to be 0 to 87,000kgCH<sub>4</sub>/PJ, which equates to 0.4%, and in industrial plants and power station the losses are 0 to 175,000kg/CH<sub>4</sub>/PJ, which is 0.8%. These leakage estimates are compounded and multiplied. The methane destruction efficiency for landfill gas injected into the natural gas transmission and distribution system can now be calculated as the product of these three efficiency factors, giving a total efficiency of (99.5% \* 99.4% \* 99.6%) 98.5% for residential and commercial sector users, and (99.5% \* 99.4% \* 99.2%) 98.1% for industrial plants and power stations.<sup>34</sup>

<sup>34</sup> GE AES Greenhouse Gas Services, Landfill Gas Methodology, Version 1.0 (July 2007).

## Appendix D Pre-Project Monitoring and Calculation of LFG<sub>PP1</sub> and PP<sub>CH4</sub>

This appendix shall be used to calculate LFG<sub>PP2</sub> and PP<sub>CH4</sub> for use in Equation 5.7. Much of the discussion here is concerned with accommodating the added complexity of monitoring passive flares and other non-qualifying devices. However, the methodology described is also applicable for measuring and documenting LFG<sub>PP2</sub> and PP<sub>CH4</sub> for calculating Closed<sub>discount</sub> (Equation 5.6).

### Baseline Monitoring

Passive flares and other non-qualifying destruction devices are often installed at landfills for purposes other than methane destruction, and therefore are not amenable to simple monitoring. For example, flares installed for odor control may be used intermittently and without any instrumentation tracking gas flow and methane concentration. This makes assessing baseline methane destruction from passive flares extremely difficult to quantify. Quantification is further exacerbated by the fact that passive flares are not necessarily designed to accommodate metering equipment; for example, in many cases passive flares do not have sufficient straight pipe length to control for turbulence. These limitations, combined with the low flow rates generally seen at passive flares greatly limit the number and type of metering equipment that can be used. Monitoring destruction of landfill gas from pre-project landfill gas wells at closed landfill flares will face fewer obstacles.

The Reserve recognizes that the constraints on monitoring landfill gas from passive flares are unique to each landfill. We have attempted to make this methodology as flexible as possible to make it widely applicable. Any deviations from this methodology will require a formal request for variance.

### Monitoring

Non-qualifying destruction devices (e.g. passive flares) and qualifying flares at closed landfills must be monitored for a period of at least three months. This period must occur prior to the project start date to ensure that the measured gas flow is not decreased by the addition of project wells or pressure changes that result from the project activity. Methane destruction from the chosen period must be extrapolated to one year based on the 90% upper confidence limit of the methane destruction identified in this period. Therefore, monitoring for more than three months, or with greater than weekly frequency, may lessen statistical uncertainty and reduce the required NQ<sub>discount</sub> or Closed<sub>discount</sub>.

Gas flow must be measured weekly at a minimum, and must be normalized to maximum flow capacity (scfm). If gas flow falls below the measurable range for the chosen metering device, the minimum flow value of the chosen metering device must be applied to that time interval. Methane concentration must also be measured at least weekly.

One measurement should be entered on each day for which readings were taken. If continuous measurements were taken, these should be averaged. If a single measurement was taken, then this value should be used. Therefore, if a daily monitoring plan is chosen for the three month period, a total of 90 data points will be available (one per day). However, if weekly measurements are taken, then only 13 data points will be available for the analysis (one per week). Alternatively, irregular measurement intervals (for example, if someone is on-site three consecutive days) or bi-weekly measurements can be used as well, allowing for anywhere

between 13 and 90 data points for any 90 day period. However, no more than one data point per calendar day may be applied and all collected data must be used.

All metering equipment used in pre-project monitoring is subject to the same maintenance, calibration, and QA/QC requirements outlined previously for project metering equipment.

## **Passive Flare Configuration**

As the configuration of passive flares will be unique to each landfill, it is not possible to dictate a single monitoring methodology. Rather, the following options have been devised as acceptable configurations.

1. Each passive flare will be monitored individually for both flow and methane concentration according to the schedule outlined in Section D.2.
2. Wells from two or more passive flares may be connected to a single flare with a single set of meters for both flow and methane concentration. Additional engineering may be required to ensure that the altered pressure characteristics of the system do not decrease total gas flow. The flow characteristics of this system will require substantiation from engineering documents and calculations and will be assessed by the verification body.
3. Wells from two or more passive flares may be connected with the active collection system and monitored separately from the new project wells while under vacuum from the blower.

## **Calculation**

Please use Equation D.1 to calculate the  $NQ_{\text{discount}}$ .

**Equation D.1.** Calculation of Pre-Project Discount for a Non-Qualifying Device

$$Closed_{discount} \text{ or } NQ_{Discount} = 525,600 \times CH_{4 \min}$$

$$LFG_{PP1} \text{ or } LFG_{PP2} = 525,600 \times 90\%UCL(LFG_{scfm})$$

Where,

		<u>Units</u>
LFG <sub>PP1</sub> or LFG <sub>PP2</sub>	= Quantity of landfill gas destroyed in the baseline in one year	scf LFG
90%UCL(LFG <sub>scfm</sub> )	= 90% upper confidence limit of the average flow rate in the metered period (must be >3 months)	scfm LFG
525,600	= Minutes in one year	min/yr

$$PP_{CH_4} = 90\%UCL(PP_{CH_4,t})$$

Where,

		<u>Units</u>
PP <sub>CH<sub>4,t</sub></sub>	= Methane concentration for pre-project calculations	scf CH <sub>4</sub> / scf LFG
90%UCL(PP <sub>CH<sub>4,t</sub></sub> )	= 90% upper confidence limit of the average methane concentration in the metered period (must be >3 months)	scf CH <sub>4</sub> / scf LFG

$$90\%UCL = mean + t_{value} \times \left( \frac{SD}{\sqrt{n}} \right)$$

Where,

		<u>Units</u>
mean	= Sample mean (of PP <sub>CH<sub>4,t</sub></sub> or LFG <sub>scfm</sub> )	scf or %
t <sub>value</sub>	= The 90% t-value coefficient for data set with degrees of freedom <i>DF</i> (use Excel feature: =TINV(0.1,DF))	
SD	= Standard deviation of the sample (of PP <sub>CH<sub>4,t</sub></sub> or LFG <sub>scfm</sub> )	scf or %
n	= Sample size	
DF	= Degrees of freedom (= n-1)	

**Example**

The following example (Table D.1) demonstrates the necessary calculation for calculation of  $Closed_{discount}$  or  $NQ_{discount}$ . The calculations outlined above in Section D.4 are represented by the first three columns of data. The final conversions to tCO<sub>2</sub>e/yr are done using Equation 5.3.

Note that although the measurements had average values yielding a deduction of 5,961 tCO<sub>2</sub>e/yr, due to the limited data and variability of the measurements, the appropriate deduction is 7,830 tCO<sub>2</sub>e/yr. If, instead of weekly data there was daily data over this three month period that yielded the exact same mean and standard deviation, the additional data alone would have lowered the deduction to only 6,807 tCO<sub>2</sub>e/yr. Alternately, if the data had been more consistent and showed a standard deviation for the flow data of only 6 with the same mean, then the deduction with 14 samples would have been only 6,689 tCO<sub>2</sub>e/yr. Therefore, the added

uncertainty deduction of this method is directly related to the level of variability in the data and the number of samples.

**Table D.1.** Example Dataset and Calculation of  $Closed_{discount}$  or  $NQ_{discount}$

	Calculated According to Equation 1 (above)				Calculated According to Equation 5-3 (protocol)	
	CH4 (%)	Flow (scfm)	Flow CH4 (scfm)	CH4/yr (scf/yr)	CH4/yr (t/yr)	t CO2e/yr
6/1/2008	56.7%	48	27	14,304,730	274	5,760
6/8/2008	55.3%	75	41	21,799,260	418	8,778
6/15/2008	58.1%	21	12	6,412,846	123	2,582
6/22/2008	54.0%	90	49	25,544,160	490	10,286
6/29/2008	55.6%	47	26	13,734,979	263	5,531
7/6/2008	56.3%	23	13	6,805,994	131	2,741
7/13/2008	57.2%	70	40	21,045,024	404	8,475
7/20/2008	58.0%	15	9	4,572,720	88	1,841
7/27/2008	52.3%	89	47	24,465,103	469	9,852
8/3/2008	55.7%	42	23	12,295,886	236	4,951
8/10/2008	54.8%	51	28	14,689,469	282	5,915
8/17/2008	62.1%	19	12	6,201,554	119	2,497
8/24/2008	59.3%	66	39	20,570,933	394	8,284
8/31/2008	57.6%	70	40	21,192,192	406	8,534
<b>Mean</b>	<b>56.6%</b>	<b>51.86</b>	<b>28</b>	<b>14,803,281</b>	<b>284</b>	<b>5,961</b>
<b>SD</b>	0.02	25.70				
<b>n</b>	14	14				
<b>DF</b>	13	13				
<b>90% t-value</b>	1.77	1.77				
<b>UCL at 90%</b>	<b>57.8%</b>	<b>64.02</b>	<b>37</b>	<b>19,443,275</b>	<b>373</b>	<b>7,830</b>

## Appendix E Data Substitution Guidelines

This appendix provides guidance on calculating emission reductions when data integrity has been compromised either due to missing data points. No data substitution is permissible for equipment such as thermocouples, which monitor the proper functioning of destruction devices. Rather, the methodologies presented below are to be used only for the methane concentration and flow metering parameters.

The Reserve expects that projects will have continuous, uninterrupted data for the entire verification period. However, the Reserve recognizes that unexpected events or occurrences may result in brief data gaps.

The following data substitution methodology may be used only for flow and methane concentration data gaps that are discrete, limited, non-chronic, and due to unforeseen circumstances. Data substitution can only be applied to methane concentration *or* flow readings, but not both simultaneously. If data is missing for both parameters, no reductions can be credited.

Further, substitution may only occur when two other monitored parameters corroborate proper functioning of the destruction device and system operation within normal ranges. These two parameters must be demonstrated as follows:

1. Proper functioning can be evidenced by thermocouple readings for flares, energy output engines, etc.
2. For methane concentration substitution, flow rates during the data gap must be consistent with normal operation.
3. For flow substitution, methane concentration rates during the data gap must be consistent with normal operations.

If corroborating parameters fail to demonstrate any of these requirements, no substitution may be employed. If the requirements above can be met, the following substitution methodology maybe applied:

Duration of Missing Data	Substitution Methodology
Less than six hours	Use the average of the four hours immediately before and following the outage
Six to 24 hours	Use the 90% lower or upper confidence limit of the 24 hours prior to and after the outage, whichever results in greater conservativeness
One to seven days	Use the 95% lower or upper confidence limit of the 72 hours prior to and after the outage, whichever results in greater conservativeness
Greater than one week	No data may be substituted and no credits may be generated

The lower confidence limit should be used for both methane concentration and flow readings for landfill projects, as this will provide the greatest conservativeness.

For weekly measured methane concentration, the lower of the measurement before and the measurement after must be used. This substitution may only be used to substitute data for a one missing weekly measurement.